

AIRMATE-12-USB

PRODUCTION | ON-AIR CONSOLE

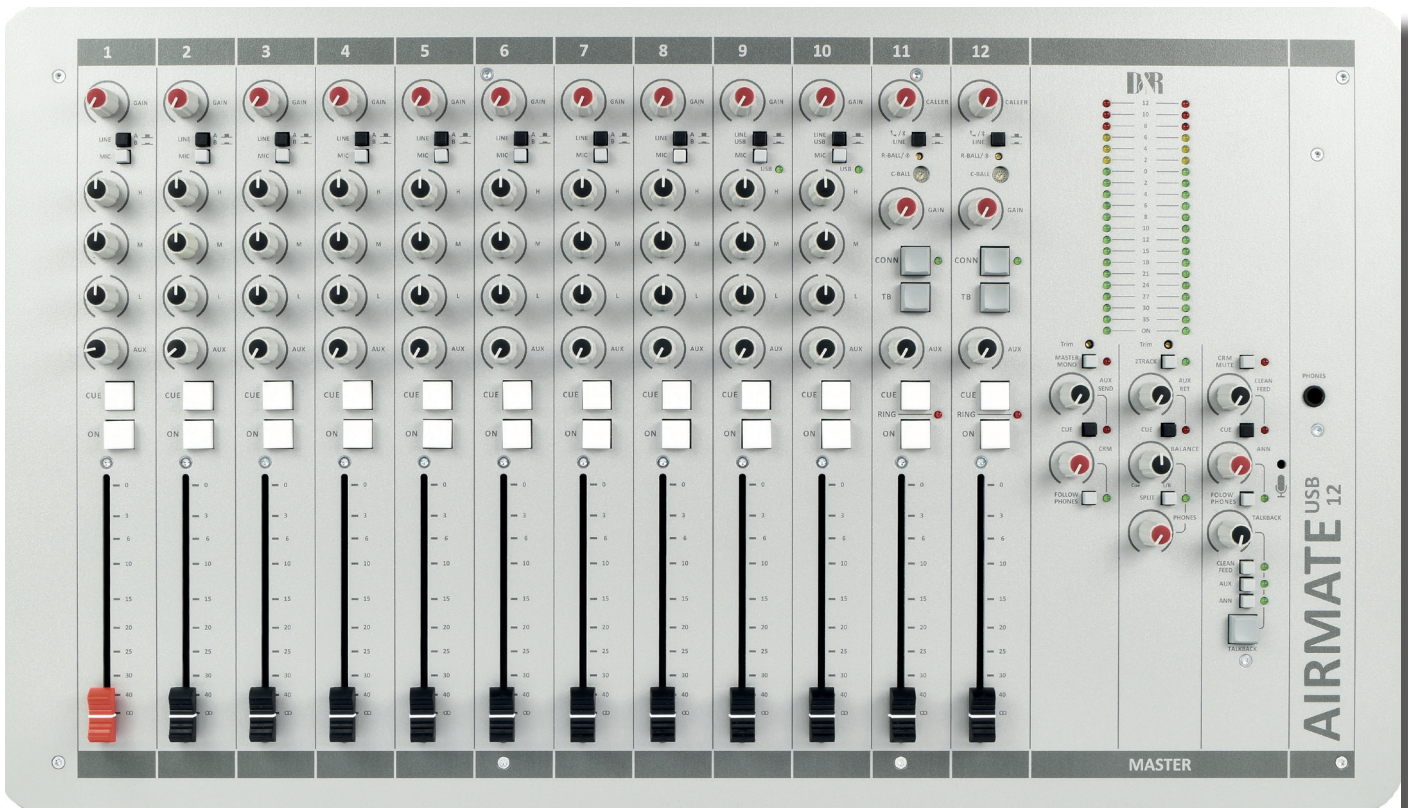

MIC, LINE, USB AND PHONE IN-OUTPUTS

Discover the Airmate-12-USB, meticulously crafted as a superior solution for broadcast mixing, offering more channels than our 8 fader AIRMATE-USB.

Engineered with robust, low-noise circuitry, this console is the ideal choice for self-operated production DJs seeking reliability, featuring internal Telephone Hybrid or VoIP connections (2x) and 2x USB connections for seamless PC streaming.

Look forward to our Wireless Phone Channel (WPC) option.

Encased in a heavy-duty RF shielded chassis, the Airmate-12-USB boasts 12 vertical triple input modules equipped with smooth-running K-ALPS faders and fader starts.

It includes ten Mic/Line input channels with eight inserts for processing, showcasing high-quality, low-noise balanced microphone inputs on XLR and two stereo line-level inputs on Cinch (RCA).

Moreover, each line-level B input can effortlessly transform into a phono (gramophone) channel by integrating an optional stereo R.I.A.A. equalized phono pre-amp on the PCB.

Introducing the new Airmate-USB 12-channel model, crafted for professional broadcasting:

- Features 8 balanced mic inputs, including +48V phantom power, with signal processor inserts.
- Includes 16 stereo line inputs, 2x USB ports, and optional 2x Telephone Hybrids (VoIP channels).
- Channels 9 and 10 offer Mic/Line inputs and USB interfaces for seamless PC audio transfer.
- Channels 11 and 12 provide stereo line inputs, RJ-11 connectors for POT line interface, and phone handset compatibility.
- High-quality built-in Hybrids with R and C balance enable direct Talkback to Hybrid channels, simplifying listener interaction.
- The front panel ON switch is integrated with a mechanical faderstart, allowing start selection via fader or hard ON switch activation.
- Faderstart in "Mic mode" triggers Mic-on signaling for external ON-Air lights.
- Channels 1-10 feature a 3-band Equalizer, while the stereo Aux send can be configured pre or post fader.
- All mic inputs include low-cut jumpers for enhanced audio clarity.
- Offers a clean feed send in the master for external GSM Hybrid integration.

MASTER SECTION DESIGNED FOR RADIO

- Discover the comprehensive features of the Airmate-12-USB, designed for seamless control and professional broadcasting:
- Includes essential master controls: stereo master faders, stereo Aux send and return, monitor master with "follow phones," and a phones output with a unique split control function.
- Equipped with a balance control for precise adjustment between main output and stereo Cue signal.
- Special Radio On-air/production section features:
- Self-op switching that automatically adjusts control room levels when DJ mic is active.
- Clean Feed output for external Telephone Hybrid integration, ideal for talk shows and interviews.
- Announcer output that can follow main output or any selected cue signal in "follow phones" mode.
- Large Talkback switch activates built-in talkback microphone for easy communication with Clean Feed output, Aux output, and/or Announcer output.



NOW IS THE TIME TO INSTALL YOUR OWN ON-AIR | PRODUCTION ROOM | WEBRADIO

The Airmate-12-USB is crafted to serve as the centerpiece for local radio production, whether in a professional studio or at home. Its intuitive features make it the perfect choice for creating dynamic radio programs quickly and efficiently.

Designed for drop-through mounting, the Airmate-12-USB offers complete reliability and comprehensive functionality, making it an ideal tool for production rooms. With up to 10 Mic channels available, it caters perfectly to studios hosting guests and featuring live music in their shows.



SUMMARY

Thank you for exploring the capabilities of the new Airmate-12 USB production/on-air console with us. If you need more details, please reach out to one of our offices or your local dealer, who will gladly provide assistance. For distributor information, visit our website at www.dnrbroadcast.com.

SPECIFICATIONS

INPUTS

- Mic inp** : balanced 2kOhm, XLR
- Phantom** : +48 volt
- Noise** : - 128 dBr (A-weighted)
- Sensitivity** : - 70dB min, 0dB max
- Insert** : Jack unbal. -10dBV
- Return** : unbalanced 10kOhm -10dBV
- Line input** : unbal., 10kOhm, Cinch
- Gain** : 40dB range with jumper for 20dB or 40dB extra gain
- Phono inp** : unbal. 47kOhm, 5 mV
- USB** : 2x Stereo in + 2x stereo out
- 2 Track return**: - 10 dBv at 10kOhm stereo
- Aux returns** : - 10 dBv at 10kOhm stereo

USB

Fully compliant with USB 2.0 playback and record mode. 2x Stereo in and 2x main stereo left right signal out on both USB connectors
HID Functions: Volume/Mute

TELEPHONE HYBRIDS

RJ-11 connectors for phone line/dialler
Mix Minus rejection @1kHz -30dB
VoIP channels are optional

OUTPUTS

- Left/Right : + 4 dBu bal. XLR
- Monitor/Aux : + 4dBu unbal. on Cinch
- Cleanfeed/Announcer: + 4dBu, Jacks
- Tape output : -10dBv, unbal. Cinch
- Headphone : 16-600 Ohm, Jack
- Announcer : 16-600 Ohm, Jack
- USB out : Main program signal

EQUALIZER

- High : + / -12 dB at 12kHz shelving
- Mid : + / -12 dB at 1 kHz bell curve
- Low : + / -12 dB at 60 Hz bell curve

OVERALL

- Frequency response: 10 - 60.000Hz
- Distortion: < 0.009% max at 1 kHz
- Start switch: Opto coupler
- Ledbars: 21 segment
- Mains input range: 100 volt up to 240volt
- Power consumption: 35VA

OPTIONS

AES-3 digital Program outputs and input.
VoIP, Wireless Phone Channel (WPC)



DIMENSIONS

Left-Right (622mm width)
Front-Back: 356mm (8HE).
Height: 95mm.
Space below front panel: 20mm for table top.
Weight: 14 kg.
For Drop through mounting cut a hole of 590 x 325 mm (console height is 95mm)

HEADOFFICE

D&R Electronica b.v.
Rijnkade 15b
1382 GS WEESP
Netherlands

Phone: +31 (0)294-418 014

Website : www.dnrbroadcast.com

E-mail: sales@d-r.nl



12 channel back panel

feels good does more

D&R Electronica BV, rijnkade 15b, 1382GS, Weesp, Netherlands
Phone: +31 (0) 294-418014, website www.dnrbroadcast.com | mail: sales@d-r.nl,

BLOCK DIAGRAM OF SIGNAL FLOW

TRIPLE INPUT MODULE

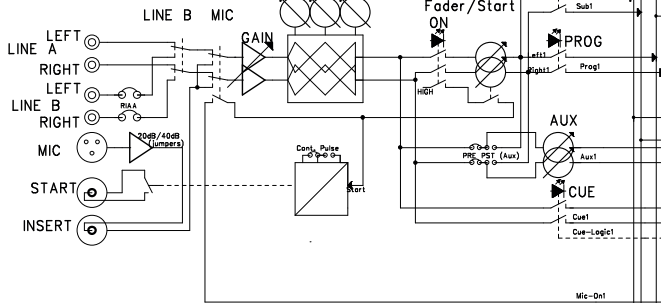

USB-LINE MODULE

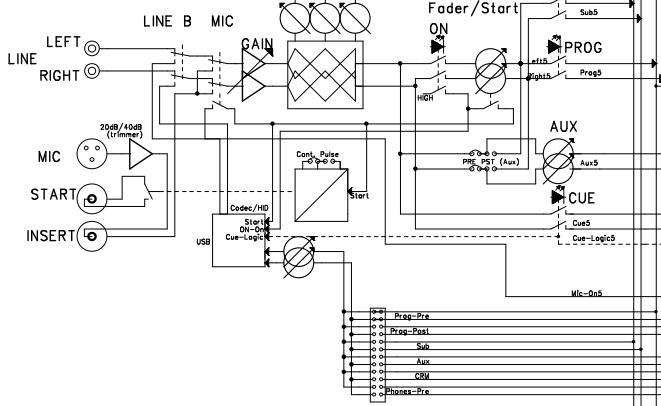

TELCO-LINE MODULE

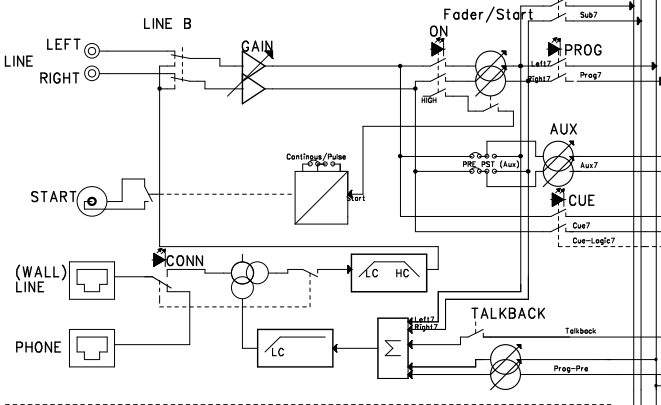

AUX RETURN

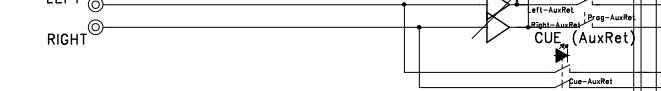

2TRACK INPUT

