

AIRLAB DT

feels good does more



User Manual

Version 1.11 WiFi

D&R ELECTRONICA BV
Rijnkade 15b
1382 GS Weesp
The Netherlands
Phone: +31 (294) 418014
Website: www.dnrbroadcast.com
E-mail: sales@d-r.nl

1. INTRODUCTION

Dear Customer,

Thank you for choosing the Airlab-DT console.

The Airlab is designed by specialists in the field of radio broadcast and is intended to be used as a 24/7 "On-Air" console as well as a production console.

We are confident that you will be using the Airlab-DT for many years to come, and wish you much success.

We always value suggestions from our clients, and we would therefore be grateful if you could complete and return the questionnaire included at the back of this manual, once you have become familiar with your Airlab. We will certainly learn from your comments, and very much appreciate your time doing this.

With kind regards,

Duco de Rijk
md

2. PACKAGE CONTENTS

The Airlab package comes with the following parts inside.

- 1x Airlab
- 1x This manual
- 1x Airlab Control Center Software on USB stick supporting Windows 7 | 8 |10 | 11
- 1x Chip card
- 1x Power cable
- 1x USB cable (for meter application and audio)
- 1x RS232 to USB cable (for programming)

AIRLAB-DT getting started

Before connecting and powering up your Airlab-DT, we strongly recommend to read the quick start manual below first.

STEP 01: Connect the RS232 to USB cable.

Connect the RS232 to USB cable between the RS232 input at the Master section of the back plain and your computer.

STEP 02: Connect the USB cable.

Connect the USB cable between the USB connection on the Master section of the back plain and your computer.

STEP 03: Connect the power cable.

It's important to check that your local mains supply corresponds with the voltage range of 90 volt up to 240 volt that the AIRLAB-DT can handle.

It is fused with a 2 Amp Slow blow fuse. DO NOT use any other value.

Connect the power cable between the Airlab-DT and a clean power outlet that has a ground.

Switch ON the Airlab-DT power on the Master section of the back plain.

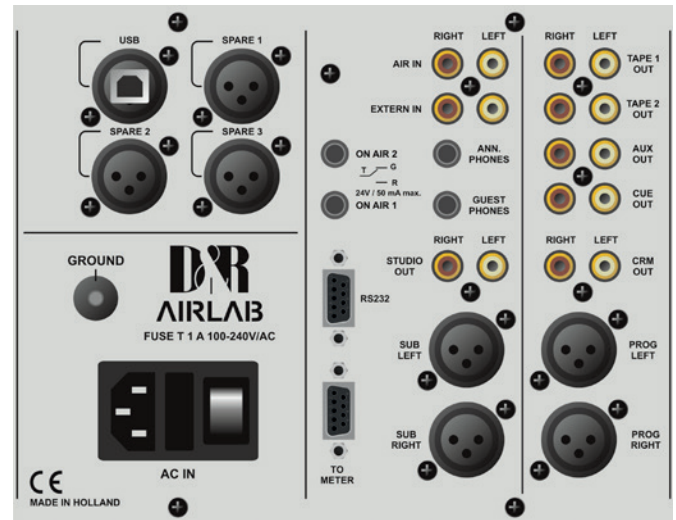

IMPORTANT:

Do NOT switch the Airlab-DT On and OFF within 10 seconds.
If switched OFF, wait for 10 seconds to allow all voltages to drop internally for a clean start.

STEP 04: Meter installing/configuration.

Install the Airlab Meters v1.61 – Setup.exe software on your computer that has been delivered on the USB-stick inside the Airlab-DT package.

Please note that you can always find the most up-to-date software of all devices of D&R on our Wiki-page: <http://www.d-r.nl/wiki/dokuwiki/doku.php>

After installation you will see the Meter application on your screen.

Pressing the Settings button on the right top of this application skin, opens up the Communication Interface window.

Now select the correct virtual serial port which will be created when the Airlab-DT is connected to your computer with the USB cable.

After this, select the appropriate server IP address and port by clicking on “Use UDP Server / Client”.

Save the settings.

STEP 05: Install Airlab Control Center Software.

With the delivered RS232 to USB cable, you be able to program your Airlab-DT from a remotely connected computer. This will give you a much better overview on all the available settings that can be made.

All custom-made settings can be saved in a file, so you can create your own personal pre-sets.

These personal settings can be saved on your own Chip card, like the one that has been delivered at the Airlab-DT package.

In this way, every user of the Airlab-DT can load his own customized settings inside the console.

Install the Airlab Control Center v3.1 – Setup.exe software on your computer that has been delivered on the USB-stick inside the Airlab-DT package.

Please note that you can always find the most up-to-date software of all devices of D&R on our Wiki-page: <http://www.d-r.nl/wiki/dokuwiki/doku.php>

During the setup you can choose the path for the installation directory.

A program folder will be created together with a desktop icon.

From this location, you can start-up the Airlab Control Center application.

For specifications of the settings, please see page 71 of the Airlab-DT User Manual.

STEP 06: Set the RC balance for Telco modules.

Power down the Airlab-DT by the switch on the Master section of the backplain.

Connect your telephone line with the “to phone” labelled female XLR and the phone appliance to the female XLR with the label “wall”. Both to be find on the backplain of the Airlab-DT at the section of the Telco channels.

Remove the Telco module out of the frame and horizontally lay down the module on the surface of the other modules. Please put isolating material between the Telco module and the surface of the other modules to avoid damage and shorts.

Locate the blue trimmer VR2 (close to switch “LINE”) on the printed board of the Telco module.

Now connect an audio source to the module. The easiest way is a 1kHz +4dB tone from a signal generator. If you don't have a signal generator you can also generate a 1kHz sine wave with Audacity on your computer. Be sure that it is +6dBu at the program output.

Connect a headphone or power amp to the TELCO SEND CINCH + connector.

Check if there is no short between the printed board of the Telco module and the surface it is put on.

Be sure that the Sub and CUE switches are OFF. (up)

Now power up the Airlab-DT by the switch on the Master section of the backplain.

Set the Send control of the Telco module to 12.0 clock, Gain set to 12.0 clock.

Dial on the connected phone appliance a telephone number outside the building or make a call to the Telco module.

Move the fader of the Telco module to the 0dB position.

Make sure that the Line In switch of the Telco module is switched off. (up)

Now press the ON switch of the module. Now the Prog and Sub switch should be activated.

If it's correct, you now hear the audio signal through the Telco module.

Now adjust the R-Bal trimmer on top of the front side of the Telco module, and set to a minimum audio position.

It is possible that you'll have to change the C balance jumpering, to be found on the printed board of the module, to a different value to get a better result.

Repeat this setup also to the other Telco modules inside the mixer.

When done, power down the Airlab-DT and install the modules properly.

As long as the Telco modules remains connected to the same phone company, no changes need to be made to this set-up.

STEP 07: Programming of the Airlab-DT.

It is possible to program your Airlab-DT by your computer using the Airlab Control Center software that you have already installed two steps ago.

In our opinion, it's better first to install your settings by hand on the Master module, so you will have a better view and a first feeling of the Airlab-DT.

Power ON the Airlab-DT.

You will now see that the display of the Master module notice the text: 00:00:00 TIMER.

This is the menu that's normally active.



Now we need to program the Airlab-DT first to your requirements.

Please be informed that during programming the AIRLAB-DT you can always save all data by simply hitting the Enter button on the front panel of the master section.

All settings are stored in the internal memory of the AIRLAB-DT.

If you leave the modules set-up section with the the ESC button, all previous stored data will still be active.

To leave the Timer menu, you have to press the UP or DOWN button in the centre of the master section.

If you do this, you'll notice the following four main menus:

- **Timer (default)**
- **Module Settings**
- **Master Settings**
- **System**

You will never see more than these four menu options.

The settings for all types of modules inside the Airlab-DT are the same. Therefore you don't see a difference between all models in programming. Only the Master module of the Airlab-DT has his own settings menu.

To program the modules to your requirements, please see page 52 of the Airlab-DT User Manual.

Now you have programmed all modules, it's time to program the Master module.

To program the Master module to your requirements, please see page 59 of the Airlab-DT User Manual.

Now you have programmed the Master module, it's time to program the System Setup.

To enter this part of the programming, hit the ENTER button to leave the Master settings with saving changes.

The System menu consists out of five submenus:

- **Configuration**
- **Recall**
- **Store**
- **Recall Memory CARD**
- **Store Memory CARD**

You can select these sub menus by pushing the *UP* or *DOWN* button.

The last two menus are only visible when you have inserted a Memory Card inside the

Master front section. This Memory Card has been delivered also inside the package of the Airlab-DT.

To program the System Settings to your requirements, please see page 60 of the Airlab-DT User Manual.

Now you have programmed the System Settings and you can start to use your Airlab-DT.

These pages are for quickstart only, for more detailed info please read the manual.

3. SYSTEM DESCRIPTION

D&R Quality

D&R has been the largest manufacturer of mixing consoles and signal processors in the Netherlands since 1972. More than 90% of the total production is exported worldwide. This market demands excellent pricing and quality standards.

D&R products are used in studios and live performances, both of which require 100% reliability, which is the result of 42 years of research, design and manufacturing.

These high standards of reliability are also to be found imbedded in the new line of broadcast mixers, which is particularly important for this type of product, required to work around the clock.

Airlab-DT Quality

The high standard of quality of the Airlab is demonstrated by the welded steel RF screening and sturdy housing, the heavy duty power supply, its modular approach and locking IDC connectors mounted on high quality double sided, plated through, glass epoxy printed circuit boards.

The signal paths are electronically switched using CMOS logic and 'FET' components, ensuring reliable and smooth switching.

High quality 100mm faders control the new redesigned "THAT" VCA's. Switching is performed by isolated encapsulated reed relays guaranteeing many years of trouble free smooth switching.

Airlab-DT flexibility

The Airlab is a specially designed production/ On-Air broadcast console. Although the design has been carefully budgeted, no compromises have been made in either quality or features, particularly in the areas of VCA control, switching, signaling, fader start/stop and communication.

The Airlab is fully modular, which means flexibility in the configuration. The Triple input modules (with or without EQ), the USB modules and digital modules as well as the Telco input modules can be placed anywhere in the chassis.

A partially loaded Airlab can be fully filled with 'blind modules'.

Digital programmable

Most of the important module functions such as module set-up as well as overall master settings are programmable and can be saved on a personal memory card or in the internal memory of the Airlab.

The LCD in the master section helps you with the programming. There is also a possibility to do this on your PC by connecting the Airlab to your PC by way of a RS232 (Airlab side) to USB (PC side) cable set that is part of the delivery.

The Airlab is a complete and self-contained piece of hardware, requiring no additional items in order to be operated.

All relevant functions are built-in, such as fader start/stop (pulse or continuously selectable). There is also no need for complex mic-on/cough switching to the announcer booth. A stereo jack, a LED and a simple push-button switch complete this task.

The optional Studio Remote is a nice looking drop through control unit for Cough switching and monitoring.

Built-in stereo headphone amp

The Airlab contains built-in headphone amps for the Announcer and Guests. No additional amps are needed.

The Studio output needs to be hooked up to a power amp that can handle +6 dBu as nominal level for full power.

Clear layout

To create a clear layout most of the switches have LED indicators, large CUE/SELECT and ON switches.

All similar functions in the triple input channels are color-coded, additional color coded fader knobs are available for personalized channel color-coding.

Example:	Microphone channels:	red fader knobs
	Telephone channels:	gray fader knobs
	Stereo channels:	black fader knobs

Radio communication

There's no radio without communication, so the Airlab has extensive possibilities for signaling and communication.

Every microphone channel has its own signaling and talk back circuitry and all outputs can also be connected to the talk back circuitry.

The announcer/technician/producer/director can communicate with the announcer booth, guests, monitoring system, all connected Telco modules and auxiliaries, either individually or in any combination.

A very intelligent CUE system connects every activated CUE switch with each other to create a transparent and intuitive communication system. It will be explained in detail further in this manual.

Signaling

It is extremely important in broadcast to know whether a microphone channel is active.

Every channel has a red light signaling available on the remote connector.

The Airlab has two external connectors for ON-AIR (mic-on) signaling to control external relays activating high voltage ON-AIR lamps or the D&R ON-AIR led light that does not need any additional circuitry to function. keep that in mind.

NEVER CONNECT 115-230 VOLT LAMPS DIRECTLY TO THE ON-AIR SIGNALING OUTPUTS IN THE MASTER SECTION!!

Broadcasting Options

In designing the Airlab, D&R decided to make the system as flexible for the operator as possible, therefore the Airlab can be used in many ways.

There's a minimum of jumper settings, which can be set to suit your own needs. Most of the settings are under software control in the master section and can be stored to a chip card.

The Airlab can be used in a traditional manner with separate control and announcer rooms, or in a more open way, whereby announcing and engineering control are carried out in one room. A self-op setup or a combination of several setups is possible.

More than one Broadcast Studio

There are numerous monitor facilities in the Airlab for external sources as well as internal sources.

The control monitors (and software meters) can be switched to follow the control room for separate (stereo) sources.

These features mean that the Airlab is specially suited to work in a studio-complex environment, where there is more than one studio/control room being used for broadcast. In this situation, the Airlab is capable of being the main On-Air console due to the two main outputs it contains. These main outputs can be fully transformer balanced as an option.

Special Recording Outputs

The Airlab has a special Recording output on a 0dBu output level.

Double Stereo Software Peak Metering application

In order to achieve a good balance between spoken words and music, it's important to be able to read the recording level accurately. The Airlab has as standard 4 Peakreading software meters reading per pair the Program output, the Sub output and the CRM output.

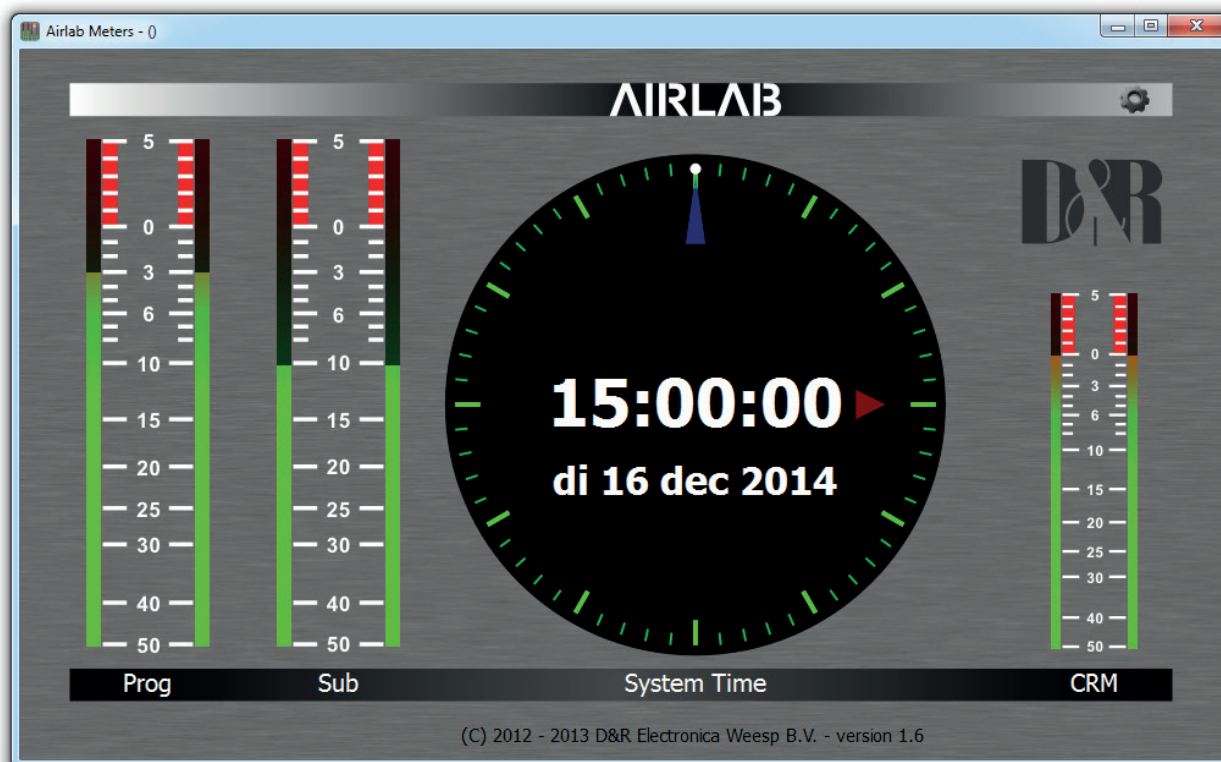

SUMMARY

Whilst using the Airlab, you'll discover its many hidden features, and will continue to appreciate its extensive capabilities.



4. TRIPLE LINE INPUT STEREO MODULE

MONO

Every channel has a mono switch with LED to send a mono input signal to both outputs of the module. (The PHANTOM POWER of 48 volt is switchable by a jumper setting (see also chapter 12))

MIC-TRIM

The trim control adds an extra 13dB of mic gain to the mic pre-amp. An optimal gain range can be accomplished in this way.

GAIN

The gain control adjusts the incoming signal level on the MIC and LINE input.

LINE A

The triple module default is in 'LINE A' mode. Operating the 'LINE B' switch or the MIC switch changes the input source selection.

LINE B

When line B is selected (with optional RIAA correction amp), the green LED is illuminated.

MIC

MIC input selector switch between MIC-input or Line-A/B input. When the LED is illuminated the MIC-input is activated. Mic overrides the Line A or B selection.

HIGH

Adjusts high frequencies with +/- 12 dB at 10 kHz shelve.

MID

Adjusts mid frequencies with +/- 12 dB at 1 kHz bell.

LOW

Adjusts the low frequencies with +/- 12 dB at 60 Hz bell.

SUB

The sub switch assigns the signal in stereo to the sub output.

PROG(RAM)

The program switch assigns the signal in stereo to the program output.

STEREO AUX

Transmits a stereo signal to the AUX master post fader. A jumper on the board determines whether this is pre or post VCA. The channel 'ON' switch also affects the aux send (only when set to post fader).

PAN

Allows adjustment between the left and right channel outputs.

CUE/SELECT

Stereo pre-fade listening; allows pre-fade listening of the channel with the fader closed.

The CUE function will be automatically TURNED OFF when the channel becomes active.

The CUE switch also generates a start/stop pulse in the line-mode.

The CUE switch also acts as a SELECT switch for the programming of the modules functions.

ON

Channel on/off switch. The Airlab is capable of sending out a pulse by ON switch as well as by fader.

This is software programmable. In any case the adjacent LED will lit when the ON switch is activated.

FADER

The linear fader controls a VCA that controls the module's overall level. The fader knob position is electronically sensed when the fader is open and generates (when programmed) the start for remotely connected devices.



5. SPECIFICATIONS OF THE TRIPLE MIC/LINE (EQ) MODULE FUNCTIONS

Microphone input: Electronically balanced
 Impedance: 2 kOhm
 Level: From -70 dBu microphone input to 0 dBu
 Connectors: XLR female, Pin 1 = ground. Pin 2 = in phase. Pin 3 = out of phase
 48 Volt phantom: Jumper enabled/disabled, (see chapter 12)
 Mic High pass filter: At 80 Hz internally set by a jumper, (see chapter 12)

REMOTE: *(Only when programmed)*
 Remote control of the channels CUE and/or Cough/Communication
 'Channel-on' light signaling. Connection by way of a stereo jack

Tip = Positive supply voltage, current limited at 6 mA when the channel is 'active (fader up)'. A direct connection to a LED is possible between tip and sleeve.
Ring = When momentarily connected to ground, the channel will be muted and CUE is activated creating a Cough/Communication function when the channel is in the Mic mode. CUE can be normally activated when in LINE mode.
Sleeve = ground.

A-Input and B-Input: The input impedance for both 'A' and 'B' are >10 kOhm, and the maximum sensitivity ranges from -20 dBu to +20 dBu. The signal to noise ratio is -90 dB (R.I.A.A. = -70 dB). Nominal level of the A input is +4dBu and for the B input 0dBu.

Connector is Jack: LINE A = balanced wired to a female XLR connector
 Pin 2 is in phase,
 Pin3 is out of phase and pin1 is ground
 LINE B = unbalanced on Cinch connectors.

NOTE: By adding an optional plug-in stereo R.I.A.A. pre-amp, the B input is able to accept M.D. phono pick-ups. See (see chapter 12)!

START: Stereo jack plug
 Tip = Center contact
 Ring = Normally open
 Sleeve = Normally close
 Maximum voltage/current that can be handled=24 volt at 50mA

NOTE: Polarity is not important with reed relays!

DO NOT CONNECT 115/230VOLT AC TO THIS CONNECTOR!!!

Pulse or Continuous Signal: Software programmable between active or not and between pulse or continue.



6. MORE DETAILED INFO VARIOUS MODULE FUNCTIONS

Mono Microphone input

The front end of this module is designed to amplify balanced microphone signals. A +48 Volt phantom power supply is available for condenser microphones. The Airlab has the ultimate in mic amplification with a wide dynamic range and extremely low noise.

The microphone input is electronically balanced and protected against R.F. interference.

Input impedance is 2 kOhm. This is high enough to accept all modern microphones.

The Gain control can vary the input levels with a range of 40dB in one turn.

The signal to noise ratio is -127.0 dB and is therefore well suited to low noise applications.

Phantom Powering

This +48 Volt power is required for condenser microphones and can be applied to the microphone inputs via a jumper setting on the PCB. (See also chapter 12)

When the phantom power is applied and the channel is active, a 'click' can be heard when a microphone is plugged in. This is due to a D.C. component on the input, which is suddenly interrupted and amplified by +/- 70 dB. It's therefore important **NOT** to do this with channel faders up and channel ON. It's even better to switch off the console entirely before connecting or disconnecting any kind of equipment.

DO NOT use unbalanced or electret microphones when the phantom power is applied as it could damage the microphones.

High-Pass Filter on MIC ON the PCB

The high-pass filter attenuates the low frequencies below 80 Hz and can be switched on or off by jumper settings (see also chapter 12). It is only active on MIC inputs.

NOTE: Some microphones have built in high-pass filters and therefore do not require use of the Airlab high-pass filter.

Microphones used for speech are usually set for high-pass filtering in order to avoid 'popping' and other unwanted low frequency rumble and therefore improve the quality and intelligibility of the spoken word.

A. COUGH / REMOTE / SIGNALING IN MIC MODE

This useful feature has two important functions:

1. Cough/Communication,
2. 'MIC-on' (CUE on)

Both functions are software programmable.

1. Cough/Communication

(A push-button needs to be connected to the ring and sleeve of the remote jack plug.)

Using the push-button during broadcast, the announcer can temporarily mute the microphone in order to cough (where the name comes from). At the same time his microphone will be routed to the CUE system, in order to give him the opportunity to communicate with the engineer/producer. Cough works on every programmed mic input.

2. 'MIC-on'

When the channel is active a voltage is applied between Tip (+) and Sleeve (0V), which can be used to activate a LED (red) or an opto-coupler.

In addition to the localized 'mic-on' signaling, there's also a master signal in the master section. The ON-AIR signaling outputs 1 and 2 offer the option of driving external red light indicators in the studio by way of external high voltage relays.

B. REMOTE/SIGNALLING IN LINE MODE

In this mode CUE can be switched on/off via a remote external push-button. When the channel is active a voltage is applied between Tip (+) and Sleeve (0V), which can be used to activate a LED (red) or an opto-coupler.

Alignment of the MIC input

With the fader in the 'down' position, and the CUE activated, the input signal is adjusted with the gain control until the 0 dB position in the master VU meter is reached. When the fader is in its 0 dB position, the signal has a nominal level in the Airlab. This way of alignment will give enough headroom to compensate for signal losses of up to 10 dB, whilst the noise floor remains well below the nominal level.

Airlab Line input module

This part of the triple input module is specially designed to accept balanced and unbalanced stereo input signals. There are two stereo inputs; line A and line B. Both inputs can have fader start functions. By changing software settings this can be accomplished.



R.I.A.A.

As an option, a stereo phono pre-amp with R.I.A.A. filter curves can be plugged onto the motherboard, in order to accept Magnetic Dynamic Phono cartridges. The Line B input will be converted.

START/STOP FUNCTIONS CONFIGURED

The 'Start' is only active when this is activated in the software.

These remote connectors are activated by the fader and/or 'ON' switch in the channel module. The start jack connectors are electronically separated by use of encapsulated reed relays.

Reed relays are ideal devices for eliminating ground loops and limited life span effects of other switches and can easily be interfaced with all modern equipment.

The start connectors are connected to separate reed relays.

The maximum VOLTAGE/CURRENT is 24v/50mA. (Polarity is not important with reed relays!)

NOTE 1: *Nearly all of the modern devices require pulse information. Continuous signals however, can have the advantage that during broadcast a CD player cannot be accidentally stopped. One disadvantage however is that some CD players are blocked from other functions when started with a continuous pulse.*

NOTE 2: *It is advisable to only use the pulse start mode with jingle machines. The cart has to finish its tape to the end and then automatically rewinds.*

NOTE 3: *Some of the older products such as the A-77, require additional relays or switching transistors to operate satisfactorily, contact your dealer for more information.*

MIC/LINE GAIN

The Gain control (only active when the line input is selected) adjusts the gain of the stereo channel pre-amps, within a range of -20 dB to +20 dB for the line level and +/-40 dB for the Mic level. The range of the fader (VCA) gives an additional 10 dB of gain when needed.

Alignment of the LINE input of a channel

To align the line input of a channel close the fader and activate the cue switch. The gain control is used to adjust the level of the incoming signal until a 0 dB reading is achieved. If the 'ON' switch is now activated, the signal level will be nominal. When the fader is opened, the CUE signal will be automatically reset, and its associated LED will switch off.

Equalizer

The equalizer is optimized for broadcast. Center detents on all equalizer controls indicate their flat position. (On special demand we could manufacture modules without an EQ section)

The maximum lift and cut is 12 dB at the following frequencies:

10 kHz:	Shelve
1 kHz:	Bell
60 Hz:	Bell

SUB

The Sub switch switches the stereo modules output to a separate SUB mix amp located in the master section of the console.

This setup makes production work possible during ON-AIR broadcast due to extremely good cross talk figures achieved in the Airlab console by careful usage of high-end CAD design systems in the initial design stage of the console.

PROGRAM

The Program switch switches the stereo modules output to the main mix amps located in the master section of the console.

Auxiliary

The stereo auxiliary send is post fader, bringing the signal to the master stereo auxiliary send. When the input module is used for microphone signals only both left and right signal paths are fed by the same mono mic input signal. The channels 'ON' switch will also switch the Auxiliary send on or off when its jumper is set to post fader.



PAN

The PAN enables adjustment between the left and right signals. The range is not restricted in order to enable to position any incoming signal anywhere in the stereo image.

CUE

This is an automatic pre-fade-listen system, which enables you to listen to a channel without actually opening that channel. When the CUE button is activated, the channel signal will be connected to the cue output and meter circuitry; the red cue LED indicator will illuminate.

When the channel is active, the CUE system will be reset, including its associated LED, however it's possible to re-activate the CUE switch.

Channel Cueing on DJ channels will only be heard in the headphone outputs. The CRM output will be muted.

The CUE switch can also generate a start pulse for remotely connected machines by software programming.

The CUE signal can be heard in two ways:

1. Through the stereo Control Room Monitors by activating the "CUE to CRM" function switch in the master section. If the cue is activated in one of the channels, the CRM and meters will be activated without interruption of the main output.
2. By way of an externally connected cue amplifier with loudspeaker.

ON

The channel on/off switch operates in tandem with the fader.

There are two methods of activating the channel:

- A. Press the 'ON' switch (Green LED is on). Then by moving up the fader, the signal is sent to the master and at the same time a mic-on/channel on indication is sent to the remote connector.
- B. When the 'ON' switch is 'OFF', no LED is illuminated. As the fader is moved upwards, the channel is put into 'stand-by'. At this point there is no "mic-on/channel on" signaling or audio to the master. Pressing the 'ON' switch activates the channel and the green LED is on.

In order to switch the channel and mic-on signaling off, the 'ON' switch should be deactivated, or the fader closed.

Fader

The fader is an ultra smooth 100mm model controlling the internal high quality VCA's and sending on/off information to the logic circuitry. There is no audio going through the faders, which guarantees noise free fading forever! When the fader is closed, the signal is automatically muted, providing a cut-off in excess of 100 dB. This high dB cut-off value ensures that the main output is protected from cross talk from announcers.

All descriptions above are also applicable for the NON EQ module (except for the EQ functions of course)



7. TRIPLE DIG INPUT MODULE

MONO

Every channel has a mono switch with LED to send a mono input signal to both outputs of the module. (PHANTOM POWER, not on the front panel. But 48 volt switch able by a jumper setting (see also chapter 12))

MIC-TRIM

The trim control adds an extra 13dB of mic gain to the mic pre-amp. An optimum gain range can be accomplished in this way.

GAIN

The gain control adjusts the incoming signal level on the MIC and DIG-LINE inputs.

LINE A

The triple-dig module default is in 'LINE A' mode (AES3). If no AES3 signal is connected or the AES3 signal can't be read, the LED will be red-flashing. Operating the 'DIG-LINE B' switch or the MIC switch changes its mode.

LINE B

When 'LINE B' is selected (S/P-dif) the green LED is illuminated. If no S/P-dif signal is connected or the S/P-dif signal can't be read, the LED will be red-flashing.

MIC

MIC input selector switch between MIC-input or Line-A/B input. When the LED is illuminated the MIC-input is activated.

HIGH

Adjusts high frequencies with +/- 12 dB at 10 kHz shelve.

MID

Adjusts mid frequencies with +/- 12 dB at 1 kHz bell.

LOW

Adjusts the low frequencies with +/- 12 dB at 60 Hz bell.

SUB

The sub switch assigns the signal in stereo to the sub output.

PROG(RAM)

The program switch assigns the signal in stereo to the program output.

STEREO AUX

Transmits a stereo signal to the AUX master post fader. A jumper on the board determines whether this is pre or post VCA.

The channel 'ON' switch also affects the aux send (only when set to post fader).

PAN

Allows adjustment between the left and right channel outputs.

CUE/SELECT

Stereo pre-fade listening; allows pre-fade listening of the channel with the fader closed.

The CUE function will be automatically TURNED OFF when the channel becomes active.

The CUE switch also generates a start/stop pulse in the line-mode.

The CUE switch also acts as a SELECT switch for the programming of the modules functions.

ON

Channel on/off switch. The Airlab is capable of sending out a pulse by ON switch as well as by fader.

FADER

The linear fader controls a VCA that controls the module's overall level. Electronics sense when the fader is opened and generates (when programmed) the start for remotely connected devices.

Digital Output

In case you have installed a digital module in your console you get a digital output for free as a bonus.

The Digital output of the console (*male XLR in the input module*) can be the **PROG**-bus or the **SUB**-bus by Jumper selectable. The output level (digital headroom) can be trimmed by the internal level trimmers (see also chapter 12).



8. SHORT OVERVIEW OF TRIPLE DIG INPUT/OUTPUT FUNCTIONS

Microphone input: Electronically balanced on female XLR
 Impedance: 2 kOhm

Level: From -70 dBu microphone input to 0 dBu

Connectors: XLR female, Pin 1 = ground. Pin 2 = in phase. Pin 3 = out of phase

48 Volt phantom: Jumper enabled/disabled, (see chapter 12)

Mic High pass filter: At 80 Hz internally set by a jumper, (see chapter 12)

Dig. A-Input: Line-A LEFT = is a digital stereo input on **female XLR**. transformer balanced 110ohm AES3 input on XLR
 Data: 24bit, 32..96kHz. Dynamic Range, S/N: 100dB
 Input level: -9dBFS = 0dBu preGain (gain +/-20dB)

Dig. B-Output: Line-A right is a digital stereo output on **Male XLR** unbalanced 75ohm S/P-dif input on Cinch (black).
 Data: 24bit, 32..96kHz. Dynamic Range, S/N: 100dB
 Input level: -9dBFS = 0dBu preGain (gain +/-20dB)

SPDIF Digital output: S/P-dif: 75ohm, unbalanced on Cinch (red).
 line A right Cinch-red Data: 24bit, 32..96kHz. Dynamic Range, S/N: 100dB

SPDIF Digital input: S/P-dif: 75ohm, unbalanced on Cinch (white).
 (ine A left Cinch-white) Data: 24bit, 32..96kHz. Dynamic Range, S/N: 100dB

The digital output frame clock (sample rate) can be setup in two different ways by internal jumper setting (see also chapter 12).
 1. Fixed. Output Frame Clock (sample rate) is always 44.1kHz
 2. PLL. Output Frame Clock (sample rate) is identical to the clock signal of the digital input.
 Jumper selectable SUB or PROG output.
 Output level: adjustable (normal 0dBu = -9dBFS)

Connector is Jack: LINE A = AES3 balanced wired to a female XLR connector
 Pin 2 is in phase,
 Pin 3 is out of phase
 Pin 1 is ground
 LINE B = S/P-dif unbalanced on Cinch connectors.

REMOTE: Stereo jack plug
 Tip = Center contact
 Ring = Normally open
 Sleeve = Normally close
 Maximum voltage/current that can be handled=24 volt at 50mA
 (wire only tip and ring of a stereo jack to switch an external function)

NOTE: Polarity is not important with reed relays!



DO NOT CONNECT 115/230VOLT AC TO THIS CONNECTOR!!!

8. SHORT OVERVIEW OF TRIPLE DIG INPUT FUNCTIONS

REMOTE: *(Only when programmed)*
 Remote control of the channels CUE and/or Cough/Communication
 'Channel-on' light signaling. Connection by way of a stereo jack

- Tip** = Positive supply voltage, current limited at 6 mA when the channel is 'active (fader up)'. A direct connection to a LED is possible between tip and sleeve.
- Ring** = When momentarily connected to ground, the channel will be muted and CUE is activated creating a Cough/Communication function when the channel is in the Mic mode. CUE can be normally activated when in LINE mode.
- Sleeve** = ground.

START: Stereo jack plug
 Tip = Center contact
 Ring = Normally open
 Sleeve = Normally close
 Maximum voltage/current that can be handled=24 volt at 50mA

Pulse or Continuous Signal: Software programmable between active or not and between pulse or continue.

NOTE: Polarity is not important with reed relays!

DO NOT CONNECT 115/230VOLT AC TO THIS CONNECTOR!!!



MIC INPUT

DIG INPUT

DIG OUTPUT

DIG OUTPUT



DIG INPUT



Mono Microphone input

The front end of this module is designed to amplify balanced microphone signals. A +48 Volt phantom power supply is available for condenser microphones. The Airlab has the ultimate in mic amplification with a wide dynamic range and extremely low noise.

The microphone input is electronically balanced and protected against R.F. interference.

Input impedance is 2 kOhm. This is high enough to accept all modern microphones.

The Gain control can vary the input levels with a range of 40dB in one turn.

The signal to noise ratio is -127.0 dBr and is therefore well suited to low noise applications.

Phantom Powering

This +48 Volt power is required for condenser microphones and can be applied to the microphone inputs via a jumper setting on the PCB. (See also chapter 12)

When the phantom power is applied and the channel is active, a 'click' can be heard when a microphone is plugged in. This is due to a D.C. component on the input, which is suddenly interrupted and amplified by +/- 70 dB. It's therefore important **NOT** to do this with channel faders up and channel ON. It's even better to switch off the console entirely before connecting or disconnecting any kind of equipment.

DO NOT use unbalanced or electret microphones when the phantom power is applied as it could damage the microphones.

High-Pass Filter on MIC

The high-pass filter attenuates the low frequencies below 80 Hz and can be switched on or off by jumper settings (see also chapter 12). It is only active on MIC inputs.

NOTE: Some microphones have built in high-pass filters and therefore do not require use of the Airlab high-pass filter.

Microphones used for speech are usually set for high-pass filtering in order to avoid 'popping' and other unwanted low frequency rumble and therefore improve the quality and intelligibility of the spoken word.

A. COUGH / REMOTE / SIGNALING IN MIC MODE

This useful feature has two important functions:

1. Cough/Communication,
2. 'MIC-on' (CUE on)

Both functions are software programmable.

1. Cough/Communication

(A push-button needs to be connected to the ring and sleeve of the remote jack plug.)

Using the push-button during broadcast, the announcer can temporarily mute the microphone in order to cough (where the name comes from). At the same time his microphone will be routed to the CUE system, in order to give him the opportunity to communicate with the engineer/producer. Cough works on every programmed mic input.

2. 'MIC-on'

When the channel is active a voltage is applied between Tip (+) and Sleeve (0V), which can be used to activate a LED (red) or an opto-coupler.

In addition to the localized 'mic-on' signaling, there's also a master signal in the master section.

The ON-AIR signaling outputs 1 and 2 offer the option of driving external red light indicators in the studio by way of external high voltage relays.

B. REMOTE/SIGNALLING IN LINE MODE

In this mode CUE can be switched on/off via a remote external push-button.

When the channel is active a voltage is applied between Tip (+) and Sleeve (0V), which can be used to activate a LED (red) or an opto-coupler.

Alignment of the MIC input

With the fader in the 'down' position, and the CUE activated, the input signal is adjusted with the gain control until the 0 dB position in the master VU meter is reached. When the fader is in its 0 dB position, the signal has a nominal level in the Airlab. This way of alignment will give enough headroom to compensate for signal losses of up to 10 dB, whilst the noise floor remains well below the nominal level.



9. Airlab Dig Line input module

This part of the triple input module is specially designed to accept balanced (AES3) and unbalanced (S/P-dif) digital input signals. There are two digital inputs; line A (AES3) and line B (S/P-dif). Both inputs can have fader start functions. By changing software settings this can be accomplished.

START/STOP FUNCTIONS CONFIGURED

The 'Start' is only active when this is activated in the software.

These remote connectors are activated by the fader and/or 'ON' switch in the channel module. The start jack connectors are electronically separated by use of encapsulated reed relays.

Reed relays are ideal devices for eliminating ground loops and limited life span effects of other switches and can easily be interfaced with all modern equipment. The start connectors are connected to separate reed relays.

The maximum VOLTAGE/CURRENT is 24v/50mA. (Polarity is not important with reed relays!)

NOTE 1:

Nearly all of the modern devices require pulse information. Continuous signals however, can have the advantage that during broadcast a CD player cannot be accidentally stopped. One disadvantage however is that some CD players are blocked from other functions when started with a continuous pulse.

NOTE 2:

It is advisable to only use the pulse start mode in case you still have jingle machines. The cart has to finish its tape to the end and then automatically rewinds.

MIC/LINE GAIN

The Gain control (only active when the line input is selected) adjusts the gain of the stereo channel pre-amps, within a range of -20 dB to +20 dB for the line level and +/-40 dB for the Mic level. The range of the fader (VCA) gives an additional 10 dB of gain when needed.

Alignment of the LINE input of a channel

To align the digital-line input of a channel close the fader and activate the cue switch. The gain control is used to adjust the level of the incoming signal until a 0 dB reading is achieved. If the 'ON' switch is now activated, the signal level will be nominal. When the fader is opened, the CUE signal will be automatically reset, and its associated LED will switch off.

Equalizer

The equalizer is optimized for broadcast. Center detents on all equalizer controls indicate their flat position. (On special demand we could manufacture modules without an EQ section)

The maximum lift and cut is 12 dB at the following frequencies:

10 kHz:	Shelve
1 kHz:	Bell
60 Hz:	Bell

SUB

The Sub switch switches the stereo modules output to a separate SUB mix amp located in the master section of the console.

This setup makes production work possible during ON-AIR broadcast due to extremely good cross talk figures achieved in the Airlab console by careful usage of high-end CAD design systems in the initial design stage of the console.

PROGRAM

The Program switch switches the stereo modules output to the main mix amps located in the master section of the console.

Auxiliary

The stereo auxiliary send is post fader, bringing the signal to the master stereo auxiliary send. When the input module is used for microphone signals only both left and right signal paths are fed by the same mono mic input signal. The channels 'ON' switch will also switch the Auxiliary send on or off when its jumper is set to post fader.

PAN

The PAN enables adjustment between the left and right signals. The range is not restricted in order to enable to position any incoming signal anywhere in the stereo image.





When the channel is active, the CUE system will be reset, including its associated LED, however it's possible to re-activate the CUE switch.
 Channel Cueing on DJ channels will only be heard in the headphone outputs. The CRM output will be muted.
 The CUE switch can also generate a start pulse for remotely connected machines by software programming.

The CUE signal can be heard in two ways:

1. Through the stereo Control Room Monitors by activating the "CUE to CRM" function switch in the master section. If the cue is activated in one of the channels, the CRM and meters will be activated without interruption of the main output.
2. By way of an externally connected cue amplifier with loudspeaker.

ON

The channel on/off switch operates in conjunction with the fader.

There are two methods of activating the channel:

A. Press the 'ON' switch (Green LED is on). Then by moving up the fader, the signal is sent to the master and at the same time a mic-on/channel on indication is sent to the remote connector.

B. When the 'ON' switch is 'OFF', no LED is illuminated. As the fader is moved upwards, the channel is put into 'stand-by'.

At this point there is no "mic-on/channel on" signaling or audio to the master.

Pressing the 'ON' switch activates the channel and the green LED is on.

In order to switch the channel and mic-on signaling off, the 'ON' switch should be deactivated, or the fader closed.

FADER

The fader is an ultra smooth 100mm model controlling the internal high quality VCA's and sending on/off information to the logic circuitry. There is no audio going through the faders, which guarantees noise free fading forever! When the fader is closed, the signal is automatically muted, providing a cut-off in excess of 100 dB. This high dB cut-off value ensures that the main output is protected from cross talk from announcers.

Digital Output:

The Airlab Triple digital input has 2 digital outputs. AES3 on the XLR and S/P-dif on the red cinch. Dependent on the jumper setting the output is giving the stereo PROG signal or the stereo SUB-signal. Normal the output level is -9dBFS but the level (headroom) can be adjusted (see also chapter 12). The digital output frame clock (sample rate) can be setup in two different ways by internal jumper setting.

- 1: PLL. Output Frame Clock (sample rate) is identical to the clock signal of the digital input (Select by the 'Line B' switch, 32..96 kHz). If the digital-input is not in lock (no input signal or a wrong signal) the Output Frame Clock will jump back to 44.1kHz.
- 2: Fixed. Output Frame Clock (sample rate) is always 44.1kHz

NOTE: In the 'PLL' mode the digital output signal will shortly be muted if you change de digital input selection ('Line B' switch) or if the digital input lose lock.

So for a Digital Main output the 'Fixed' setting is recommended.

At connecting for instance a DAT or MD player/recorder, the 'PLL' setting can be used.

In PLL mode:

In the 'PLL' mode the digital output sample-rate is in sync with the digital input.

If no digital input signal is connected or selected (Line-B LED will be RED-flashing) the output frame clock will be 44.1kHz.

If a digital input signal is connected and selected the Line-B LED well be GREEN (Line B select) or off (Line A select). The output frame clock well be equal to the digital input frame clock.

In Fixed mode:

The digital output frame clock will be fixed at 44.1kHz.

10. TELCO MODULE

R BAL TRIM

The trim control adjusts the optimum side-tone suppression (R-balance).
The trim needs to be re-adjusted with every new installation.

TELCO SEND

The Telco send controls the outgoing signal to the caller. This can be either the MIX and/or Sub output dependent upon the SUB/PROG switch settings in the Telco module. This switch not only controls the assignment of the incoming signal to the masters but also which signal is sent to the caller.

GAIN

The Gain control adjusts the gain of the incoming phone call within a range of -20 dBu to +20 dBu. The range of the fader (VCA) gives an additional 10 dB of gain when needed.

LC (Low Cut)

The high pass filter smoothly filters out all frequencies below the pass band of the telephone line.

HC (High Cut)

The low pass filter effectively filters out all above telephone line frequency passband.

CONNECT

This LED indicates the internal Hybrid is active.

SUB

The SUB switch switches the Telco modules output to the SUB mix amps located in the master section of the console.

PROGRAM

The PROGRAM switch switches the stereo modules output to the main mix amps located in the master section of the console.

Auxiliary

The stereo auxiliary sends a post fader signal, dependent upon the 'ON' switch of the input channel, to the master auxiliary busses. The PAN control creates a stereo image in the Aux masters. This setup makes production work possible during ON-AIR broadcast.

PAN

The PAN enables positioning of the incoming caller signal. The range is not restricted in order to enable to position any incoming signal anywhere in the stereo image.

CUE/SELECT/RING

Automatic pre-fade listening/post pan, or cue, allows a caller to be heard without being in the broadcast. When activating the cue switch, the caller is connected to the CUE bus and listens to the talk back MIC of the engineer (fader closed).

The CUE switch shows an incoming call by a flashing CUE LED. Hitting the CUE switch makes a connection as described above. A remote switch can pick up a call by wiring the remote connector of the Telco module.

The 'ON' switch works in conjunction with the fader switch.

If the green LED is on, the channel is 'active'.

There are two methods of activating an incoming call:





A. If the 'ON' switch is pressed, the green ON LED and the "CONNECT" LED will illuminate and the caller is connected to the Telco module but not yet heard in the broadcast because the fader is still down. By opening the fader, the Telco module will be activated and the signal will enter the program. When the fader is closed again the program signal will be muted, when the fader is at its lowest position.

B. When the 'ON' switch is not pressed, no LED is illuminated even if the fader is now opened. In this situation, none of the signals are active but as soon as the ON switch is activated (with a flashing CUE/RING switch) the caller will be "On-AIR". All switching is carried out electronically and free of noise for years to come. If the CUE function is active, it will be disabled when the channel is activated.

ON

Channel on/off switch. While in closed fader stand-by mode, i.e. when green LED is off incoming calls can be connected by pressing the "ON" switch.

FADER

Channel VCA volume-control adjusts overall channel level.

The Airlab is fitted with a modern ultra-smooth linear fader controlling a high quality VCA and the Airlab internal logic circuitry. This system eliminates any noise from disturbing the audio signal path. When the fader is closed, the signal will be automatically muted, which provides excellent fader attenuation in excess of 100dB.

An internal telephone hybrid circuit simplifies connection of telephone lines and phone appliances. There is a LINE input to accept external hybrids, a WALL connector for connecting to the telephone line and a "TO PHONE" output that connects to the phone device.

Jumpers

Aux send pre/post and C balance are jumper enabled/disabled. All other functions are software programmable.

NOTE: In the Telco module it is not possible to "Cue" when the channel is up and the module is ON.

COMMUNICATION WITH TELCO MODULE

ENGINEER TO/FROM TELCO

Communication with the engineer is easily accomplished by activating the CUE switch in the Telco module. An open communication is achieved now between caller and engineer.

ANNOUNCER TO/FROM TELCO

The CUE switch on the Telco module has to be activated. The moment the Announcer hits his cough switch communication takes place between announcer and caller (Telco module).

There are several software programmable functions available here. In chapter 14 you can find detailed information about the programmable options of the Airlab.

ALIGNMENT OF THE CHANNEL

With the fader closed (or muted channel) the CUE switch will be activated; the CUE to CRM function in the master section must be activated. The gain control is used to adjust the level of the incoming signal until a 0 dB reading is achieved. If the 'ON' switch is now activated, the signal level will be nominal. When the fader is opened, the CUE signal will be automatically reset (turned off), and its associated LED will be switched off.

The CUE signal can be heard in two ways:

1. Through the stereo Control Room Monitors by activating the CUE to CRM function in the master section. If the CUE is activated in one of the channels, the CRM and meters will be activated without interruption of the main output.
2. By way of an externally connected CUE amplifier with loudspeaker.



11. VoIP-LINE MODULE

If you have ordered a VoIP module, see below how it works.

Highlights are:

- * High quality Telephone Hybrid circuit to directly connect to the Internet.
- * Mono line input.
- * Gain control.
- * VoIP/Telco send Control.
- * Direct access CONNECT and TB (Talk Back) switches in the master section.
- * Stereo Aux send.
- * Stereo CUE switch for pre fade listening.
- * Start (ON) switch and 100mm smooth professional fader.

VoIP-CHANNEL

In the AIRLAB-DT we have built in an interface that let you connect to the Internet community by way of (for instance) Skype. Skype is free available communication software that can be used to call and receive calls of your listeners to your broadcast station. We have designed a separate USB connector on the backpanel of your console to interface with SKYPE software. This could be on the same PC (on a second USB connector) as the Play-out system is installed or on a separate PC for dedicated use of the VoIP channel with SKYPE software. For downloading the SKYPE software go to <http://www.skype.com> and then to your own language for more support. There are some SKYPE software settings you need to go through before this is working with your console. For some usefull instructions go to:

<https://support.skype.com/nl/faq/FA34541/een-perfect-skype-gesprek-voeren>

(Dutch instruction video, but I am sure there is one in your own language or in English of course).

VoIP (TELCO) SEND

With this level control the outgoing signal from the mixer is sent to the caller via Skype or and via an external connected Hybrid. This is for both the VoIP and the Stereo Line input (when selected). This Hybrid get's it send signal from the cleanfeed output on the back of the console.

TELEPHONE/LINE SWITCH

When switched to the VoIP (Phone) up position only the VoIP signal is received. When this switch is down, you have a high impedance mono line level input for connecting an external Hybrid.

GAIN

With the GAIN control, the source level is adjusted to the internal mixer level. This is for both the VoIP and the Mono Line input (when selected)

LC/HC

These switches add a lowpas and or a highpass filter to the signal to improve the sound.

CONNECT

This red led indicats when a VoIP connection is made.

SUB

The SUB switch switches the Telco modules output to the SUB mix amps located in the master section of the console.

PROGRAM

The PROGRAM switch switches the stereo modules output to the main mix amps located in the master section of the console.



Auxiliary

The auxiliary sends a post fader signal, dependent upon the 'ON' switch of the input channel, to the master auxiliary busses. The PAN control creates a stereo image in the Aux masters. This setup makes production work possible during ON-AIR broadcast.

PAN

The PAN enables adjustment between the left and right signals. The range is not restricted in order to enable to position any incoming signal anywhere in the stereo image.

CUE

This is an automatic pre-fade-listen system, which enables you to listen to a channel without actually opening that channel. When the CUE button is activated, the channel signal will be connected to the cue output and meter circuitry; the red cue LED indicator will illuminate.

When the channel is active, the CUE system will be reset, including its associated LED, however it's possible to re-activate the CUE switch.

Channel Cueing on DJ channels will only be heard in the headphone outputs.

The CRM output will be muted.

The CUE switch can also generate a start pulse for remotely connected machines by software programming.

The CUE/SELECT switch can also be used to pick up an incoming phonecall.

The Talkback will be activated at the same time.

When you move the fader upwards the program signal will be sent to the caller. (the ON switch should also be active)

The CUE signal can be heard in two ways:

1. Through the stereo Control Room Monitors by activating the "CUE to CRM" function switch in the master section. If the cue is activated in one of the channels, the CRM and meters will be activated without interruption of the main output.
2. By way of an externally connected cue amplifier with loudspeaker.

ON

The channel on/off switch operates in conjunction with the fader.

There are two methods of activating the channel:

- A. Press the 'ON' switch (Green LED is on). Then by moving up the fader, the signal is sent to the master and at the same time a mic-on/channel on indication is sent to the remote connector.
- B. When the 'ON' switch is 'OFF', no LED is illuminated. As the fader is moved upwards, the channel is put into 'stand-by'. At this point there is no "mic-on/channel on" signaling or audio to the master. Pressing the 'ON' switch activates the channel and the green LED is on.

In order to switch the channel and mic-on signaling off, the 'ON' switch should be deactivated, or the fader closed.

Fader

The fader is an ultra smooth 100mm model controlling the internal high quality VCA's and sending on/off information to the logic circuitry. There is no audio going through the faders, which guarantees noise free fading forever! When the fader is closed, the signal is automatically muted, providing a cut-off in excess of 100 dB. This high dB cut-off value ensures that the main output is protected from cross talk from announcers.

Auxiliary

The auxiliary sends a post fader signal, dependent upon the 'ON' switch of the input channel, to the master auxiliary busses. The PAN control creates a stereo image in the Aux masters. This setup makes production work possible during ON-AIR broadcast.

PAN

The PAN enables positioning of the incoming caller signal. The range is not restricted in order to enable to position any incoming signal anywhere in the stereo image.

CUE/SELECT/RING

Automatic pre-fade listening/post pan, or cue, allows a caller to be heard without being in the broadcast. When activating the cue switch, the caller is connected to the CUE bus and listens to the talk back MIC of the engineer (fader closed).

The CUE switch shows an incoming call by a flashing CUE LED. Hitting the CUE switch makes a connection as described above. A remote switch can pick up a call by wiring the remote connector of the VoIP module.

The 'ON' switch works in conjunction with the fader switch.

If the green LED is on, the channel is 'active'.

There are two methods of activating an incoming call:

RING (LED)

This LED lights to alert you when a call comes in. You can also connect a warning light to the START jack to be visually informed that a call comes in (when you wear headphones).

ON

The ON switch is used to activate the module. This switch sends out a momentary pulse (default) or switches permanently (continuously) between tip and ring of the Start connector on the back of the console. You can also use this START connector to control an external Ring indicator that a call is coming in. This is the default setting of the related jumper. You will notice that the internal LED of the ON switch will not light when pushed as long as the fader is not up alerting you that there is no signal sent to the busses (Program or Sub).

FADER

Final control of the channel is the 100mm long throw K-Alps stereo channel fader with integrated fader start switch. The channel fader sends the amount of signal from the associated channel to the master mix buss.

At the right side of the fader you see a dB labelling starting at the top with no attenuation (0) and sliding down it attenuates in steps of 5dB until it reaches a full cut off below -90dB. When you are used to fully throw the fader in its top position when opening a channel it is advisable to set the fader gain jumper to 0dB (factory default). If you need a little bit of "playground" for your audio, set the jumper to +10dB fader gain and see the -10dB (10) position as your unity gain position. At the beginning of the fader movement you will feel an internally built in start switch that is activated when you bring up the fader. This switch activates the start circuitry and controls externally connected devices such as CD players etc (via the Start connector on the back).

INPUT CONNECTORS VoIP

On the back of each of the AIRLAB-DT you find seven connectors. An balanced mono line input. The level can be set using the gain control to match most source levels. Then you see a USB connector that needs to be connected to a PC where Skype runs. The next connector is a male XLR connector that sends a cleanfeed signal (N-1) to external Hybrids if needed. The left Cinch connector is not connected, the right Cinch connector also sends a N-1 (Cleanfeed) signal. Then there is the Studio remote connector and the Start switch (GPO)

The START switch has two active connections to be wired. The tip and ring are shorted when the ON switch or fader switch is activated. Default the tip and ring are shorted when a call is coming in to alert someone is calling the studio. In case Fader start is jumpered, you can use this connector to activate an external ring indicator such as our D&R PHONE light.

NEVER CONNECT ELECTRICAL POWER TO THIS REMOTE-JACK

Connections on the START connector should only be made with a maximum of 24 Volts by 50 mA. Please contact your dealer in case of doubt.





12. TRIPLE USB INPUT MODULE

MONO

Every channel has a mono switch with LED to send a mono input signal to both outputs of the module. (PHANTOM POWER, not on the front panel. But 48 volt switch able by a jumper setting (see also chapter 12))

MIC-TRIM

The trim control adds an extra 13dB of mic gain to the mic pre-amp. An optimum gain range can be accomplished in this way.

GAIN

The gain control adjusts the incoming signal level on the MIC and DIG-LINE inputs.

LINE A

The triple-USB module default is in 'LINE A' mode (USB. If no USB signal is connected or the USB signal can't be read, the LED will be red-flashing. Operating the 'USB-LINE B' switch will not change this mode.

The MIC switch changes its source selection to Mic.

LINE B

This line B input and switch shall not function when USB electronics are fitted.

MIC

MIC input selector switch between MIC-input or Line-A input. When the LED is illuminated the MIC-input is activated.

HIGH

Adjusts high frequencies with +/- 12 dB at 10 kHz shelve.

MID

Adjusts mid frequencies with +/- 12 dB at 1 kHz bell.

LOW

Adjusts the low frequencies with +/- 12 dB at 60 Hz bell.

SUB

The sub switch assigns the signal in stereo to the sub output.

PROG(RAM)

The program switch assigns the signal in stereo to the program output.

STEREO AUX

Transmits a stereo signal to the AUX master post fader. A jumper on the board determines whether this is pre or post VCA.

The channel 'ON' switch also affects the aux send (only when set to post fader).

PAN

Allows adjustment between the left and right channel outputs.

CUE/SELECT

Stereo pre-fade listening; allows pre-fade listening of the channel with the fader closed.

The CUE function will be automatically TURNED OFF when the channel becomes active.

The CUE switch also generates a start/stop pulse in the line-mode.

The CUE switch also acts as a SELECT switch for the programming of the modules functions.

ON

Channel on/off switch. The Airlab is capable of sending out a pulse by ON switch as well as by fader.

FADER

The linear fader controls a VCA that controls the module's overall level. Electronics sense when the fader is opened and generates (when programmed) the start for remotely connected devices.

USB INPUT

The Digital USB input is either connected to an USB connector on the back or internally wired to the USB hub in the console that accepts up to 4 USB channels. Its output could be the PROG-bus or the SUB-bus and is Jumper selectable.



13. MODULE CONNECTORS

MIC Input / From Hybrid

Connector type is female XLR: Pin1 = ground
Pin2 = in phase
Pin3 = out of phase

LINE A LEFT / DIG-IN (AES3) / WALL

Connector type is female XLR: Pin1 = ground / ground
Pin2 = in phase / A (wire)
Pin3 = out of phase / B (wire)

LINE A RIGHT / DIG-OUT (AES3) / TO PHONE

(this XLR is now a Male for digital)

Connector type is (fe)male XLR: Pin1 = ground/ground
Pin2 = in phase / phone line A-wire
Pin3 = out of phase / phone line B wire

The input impedance for 'Phone' is optimized for correct loading of modern telephone stations.

LINE B INPUT / DIG-B IN/OUT (S/P-dif) / TELCO OUTPUT

Connectors are Cinch: Cinch A= left in/DIG-OUT / Telco out, in phase (+)
Cinch B= right in/DIG-IN / Telco out, out of phase (-)

REMOTE

The remote connector lets you activate the CUE of the module / Telco module when the module is in its "off" or "standby" mode.
An ON LED can be connected to the remote to indicate the "ON" status of the Telco module.
The same LED indicates incoming calls by flashing.

REMOTE - Input

Connector type is jack: Tip = Channel "ON" LED
Ring = CUE control
Sleeve = Ground

START

Connector type is jack: REED RELAY MAX VOLTAGE 24VOLT/50mA
Tip = Center contact
Ring = Normally open
Sleeve = Normally closed

(In case you have a newer SMD type of module, it is also possible to monitor a ring signal on this jack by connecting the tip and ring of a stereo jack to a signalling device such as our ON-AIR light).

MIC INSERT

Connector type is jack: Tip = Channel SEND
Ring = Channel RETURN
Sleeve = Ground

IMPORTANT

In case you want to set up a VOIP connection, we advise to use the **CISCO SPA112** as interface between the Telco modules and the Internet.



Connections on a module

14. Phone-Line module

The Wireless Phone Channel (WiFi)-Line module allows phone calls as well as stereo audio streaming from the connected Phone device. An external phone hybrid can be connected as well, providing two ways of establishing phone calls with the same module (see also 'Line').

TELCO SEND (knob)

This sets the level of the sound returning to the caller. This can be either the MIX and/or Sub output, determined by the SUB/PROG switch settings - see below. These switches control the assignment of the incoming signal to the masters as well as the signal to the caller.

Line (button + led) The LINE input selects either the Line input (led on) or the Phone channel.

The line input can be used for any audio source, including an external telephone hybrid. The Cleanfeed output provides the signal back to the caller on the external hybrid.

GAIN (knob)

The Gain control adjusts the gain of the incoming signal (being either a phone call, audio played via Bluetooth or a line input signal) within a range of -20 dB to +20 dB.

The range of the fader provides an additional 10 dB of gain when needed.

LC (pushbutton)

The high pass filter smoothly filters out all frequencies below the pass band of the telephone line.

HC (pushbutton)

The low pass filter filters out all above telephone line frequency passband.

CONNECT (LED)

This led has several functions:

- Off: no connection with a Phone;
- After pushing the Cue/Select button for three seconds the LED will blink red, indicating the Module is in discovery mode – ready to connect to a Phone.
- RED constant: connected to a Phone.
- After picking up a phone call the led turns green. When the call has ended, the led turns red again indicating the Bluetooth connection is still established.

SUB (pushbutton)

The SUB switch connects the modules output to the SUB mix bus in the master section of the console.

PROGRAM (pushbutton)

The PROGRAM switch activates the module output to the program mix amps in the master section of the console.

Auxiliary (knob)

The stereo auxiliary sends a pre or post fader signal, dependent upon the 'ON' switch of the input channel to the master auxiliary busses.

This setup makes production work possible during ON-AIR broadcast.

PAN (knob)

The PAN enables left-right positioning of the incoming caller signal. The PAN control creates a stereo image in the Aux master, Program or – in case of a stereo signal – acts as a balance control.





Phone-Line module

CUE/SELECT/RING (pushbutton + led)

Automatic pre-fade listening/post pan, or cue, allows a caller to be heard without being in the broadcast. An incoming call is showed by the red flashing Cue/Ring led.

When pushing the Cue switch, the caller is picked up, routed to the CUE bus and listens to the talk back MIC of the engineer (fader closed).

In addition, this button is used to activate the discovery (pairing) mode of the Bluetooth module by keeping it pressed for at least three seconds.

A remote switch can pick up a call by wiring the remote connector of this Module.

ON (switch)

The 'ON' switch works in conjunction with the fader switch.

If the green LED is on, the channel is 'active'.

There are two methods of picking up an incoming call:

A. If the 'ON' switch is pressed, both the green ON LED and the CONNECT LED will illuminate green and the caller is established with the Module, but not yet heard in the broadcast because the fader is still down.

By opening the fader, the Module will be activated and the signal will enter the program.

When the fader is closed again the program signal will be muted, when the fader is at its lowest position.

B. When the 'ON' switch is not pressed, the LED stays off even if the fader is opened. In this situation, none of the signals are active but as soon as the ON switch is activated (with a flashing CUE/RING switch) the caller will be "On-AIR".

If the CUE function is active, it will be disabled when the channel is activated.

ON

Channel on/off switch. While in closed fader stand-by mode, i.e. when green LED is off incoming calls can be connected by pressing the "ON" switch.

FADER

Channel VCA volume-control adjusts overall channel level.

The Airlab is fitted with a modern ultra-smooth linear fader that operates a DC signal only.

This system eliminates any noise from disturbing the audio signal path.

When the fader is closed, the signal will be completely muted, which provides excellent fader attenuation in excess of 100dB.

The Bluetooth module allows phone calls as well as stereo audio streaming from the internal Bluetooth device.

Jumpers

1. Aux send: pre or post fader (J7-8).
2. GPO function: Fader Start or Bluetooth Ring (J4).

Other functions are software programmable.

NOTE: In this module it is not possible to "Cue" when the channel is up and the module is ON.

COMMUNICATION WITH Phone-Line Module

ENGINEER TO/FROM Phone-Line

Communication with the engineer is easily accomplished by activating the CUE switch of the Module.

An open communication is achieved now between caller and engineer.

ANNOUNCER TO/FROM Phone-Line

The CUE switch on the Module has to be activated. The moment the Announcer hits his cough switch communication takes place between announcer and caller (Bluetooth-Line module).

There are several software programmable functions available here. In chapter 14 you can find detailed information about the programmable options of the Airlab.

The CUE signal can be heard in two ways:

1. Through the stereo Control Room Monitors by activating the CUE to CRM function in the master section. If the CUE is activated in one of the channels, the CRM and meters will be activated without interruption of the main output.
2. By means of an externally connected CUE amplifier with loudspeakers.

Phone-Line module

ALIGNMENT OF THE CHANNEL

With the fader closed (or muted channel) the CUE switch will be activated; the CUE to CRM function in the master section must be activated.

The gain control is used to adjust the level of the incoming signal until a 0 dB reading is achieved.

If the 'ON' switch is now activated, the signal level will be nominal.

When the fader is opened, the CUE signal will be automatically reset (turned off), and its associated LED will be switched off.

The CUE signal can be heard in two ways:

1. Through the stereo Control Room Monitors by activating the CUE to CRM function in the master section.

If the CUE is activated in one of the channels, the CRM and meters will be activated without interruption of the main output.

2. By means of an externally connected CUE amplifier with loudspeakers.



Connections on a module

Line input Left (balanced)

Line input Right (balanced)

Cleanfeed out (balanced)

Line inputs (unbalanced)

Comm

GPO start/ring

INSERT n.c.

The remote connector lets you activate the CUE of the module when the module is in its "off" or "standby" mode. An ON LED can be connected to the remote to indicate the "ON" status of the Bluetooth module. The same LED indicates incoming calls by flashing.

The START switch has two active connections to be wired.

The tip and ring are shorted when the ON switch or fader switch is activated. Default the tip and ring are shorted when a call is coming in to alert someone is calling the studio. In case Fader start is jumpered, you can use this connector to activate an external ring indicator such as our D&R PHONE light.



14. MASTER SECTION

TAPE SEND

This section of the master houses the switches and controlling what's going to the RECORDING outputs.

TAPE SEND

This section of the master houses the switches and controlling what's going to the RECORDING outputs. A selection can be made between three outputs of the Airlab. With all switches up the main program signal is recorded. As soon as one of the other switches is pressed, the corresponding FROM SUB or FROM AUX. output signals are recorded.

NOTE: With this circuitry it is possible to record stereo sources from the channels assigned to the sub buss during broadcast.

AUX OUT STEREO

This is a stereo output of the AUX masters. The level is +6dBu.

The corresponding talk back switch sends the talk back signal to both outputs.

NOTE: Overall level of Aux. outputs also affects the talk back level for these outputs

only.

CRM

The CRM is normally following the Program output unless one of the input bank switches is active.

EXT(ERN)

This stereo input can be used for any stereo source that needs to be monitored in the CRM outputs. The input level is set to be 0dBu.

AUX

This input source switch lets you listen to the stereo Aux. outputs.

(FROM) AIR

This is the input select for the CRM/phones output. Either the program mix is heard in the CRM/phones or the 'from air' signal.

(FROM) SUB

This is a stereo switch bringing the Sub output into the CRM/phones output. It will override the 'from air' and other selected sources when selected.

CUE BALANCE

The CUE balance pot continuously adjusts the balance between the stereo CUE signal and the stereo input selection made with the switches described above.

(AUTO)CUE

This LED indicates that both CRM outputs are automatically connected to a selected CUE switch in stereo. When this LED is not active the CRM will monitor the main program outputs. The CUE signal will always be present at the CUE output jack when programmed.

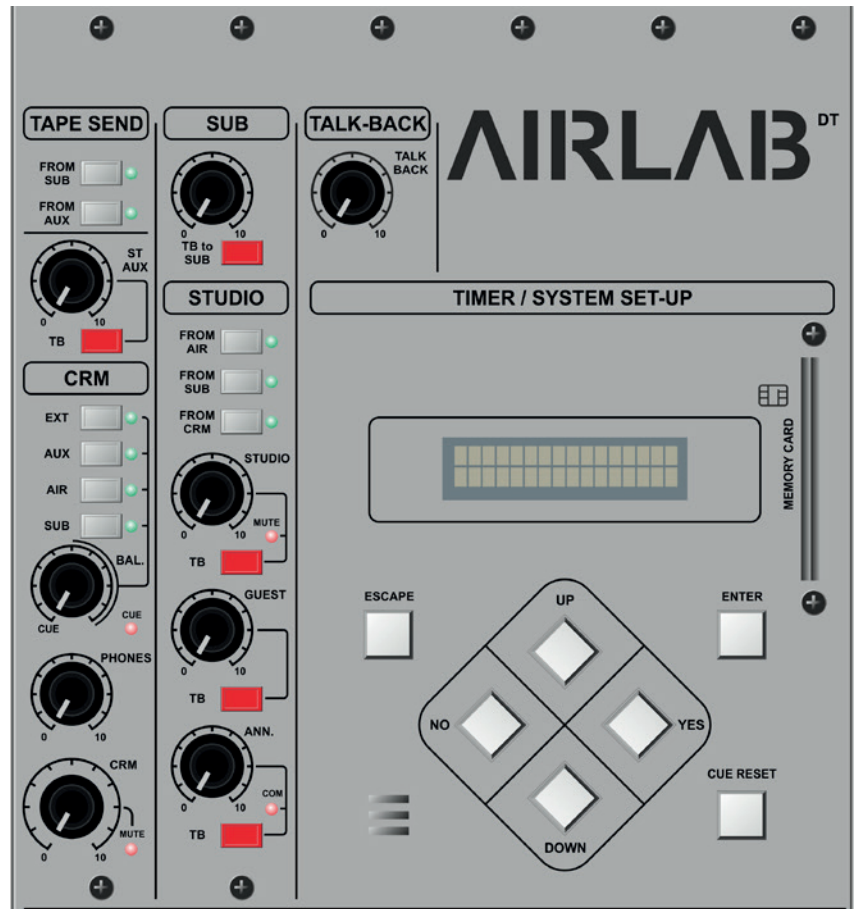

PHONES LEVEL

This controls the overall level of the stereo headphones output. A headphone socket is conveniently placed just beneath the armrest.

CRM

The control room monitor controls the outgoing level to the control room monitors. The level is +6dBu on a cinch connector. A mute LED indicates when the CRM is muted. This is the case when the Airlab is used as “self op” mixer. The DJ channel forces the CRM to mute when the Microphone is active in the control room itself. This is software configurable.

TALKBACK

This section houses most of the controls needed to communicate with every connected source to the Airlab. Communication is one of the most important parts of a broadcast, inside and outside the console. We have put a great deal of our thoughts into this part of the console.

The talk back microphone is a built in Electret microphone with its associated level control. The mic-amp is protected against clipping. The talk back switches are momentary so leaving talk back mics open is a thing of the past. The talk back mic can be assigned to several outputs at the same time when more than one switch is activated. The Studio, Guest and Announcer outputs are driven post their volume controls, so communication is always possible. Talk back to the SUB output is possible with the talk back switch positioned in the SUB section of the master.

STUDIO

In the Studio area are three monitor systems, of which you can choose from and that suits your particular situation. The studio output will give a stereo signal fed from the “PROGRAM” signal or from one of the selected other input sources, such as (from)AIR, (from)SUB or the CRM. The associated MUTE LED indicates that a microphone is opened in the Studio area avoiding feedback. The programming of this function is under software control.

The Studio Talkback switch instantly injects the talk back signal from the internal Electret microphone into the studio output independent of the studio level settings. The studio output can be used as an overall output to monitor what’s going on during broadcast in the studio room itself. The studio output is wired to a stereo cinch connector.

GUEST

The GUEST output is stereo and follows the program signal unless the input selection of “from AIR”, “from SUB” or “From CRM” is activated. A separate stereo headphone output is provided for a guest and the talk back is always addressed to both earphones independent of level settings. The program material will be dimmed when the talk back is activated. The output is identical to that of the announcer and could therefore be used as a second announcer’s output. The Guest Talkback switch instantly injects the talk back signal from the internal Electret microphone into the GUEST output independent of studio level settings.

ANNOUNCER

The ANNOUNCER output is stereo and follows the program signal unless the input selection “From air”, “From sub” or “From CRM” is activated. A separate stereo jack socket is provided for the announcer and the talk back is always addressed to both earphones independent of level settings. The Announcer Talkback switch instantly injects the talk back signal from the internal Electret microphone into the Announcer output independent of studio level settings.

COM

A COM(munication) LED is placed nearby the Announcer control to indicate that the talk back is activated. This is accomplished by pressing the Cough switch on the SiCo remote box, when installed.



15. CONTROL SECTION

Besides the audio channels the Airlab mixer is equipped with a control section. This control section is located at the right of the mixer and consists of 24 illuminated switches and a rotary encoder with push switch. The switches are able to illuminate red, green, and yellow to indicate various conditions. Each switch contains a label which can be customized to customer needs.

Why a control module?

A frequently desire in the broadcast world is to control specific playout software by an external hardware device since the user prefer to have direct and accurate control over the controlled application. In order to be able to control such a software application from unlike mouse or keyboard, one normally needs an external hardware device which is user friendly to operate and is able to communicate with the relevant application.

The Airlab mixer can benefit from an integrated control module whereby investments in external equipment is unnecessary. The control section provides a sufficient number of switches to control any playout software, for example starting and stopping jingle players. With the rotary encoder at the top one is able to scrolling through and selecting parameters.

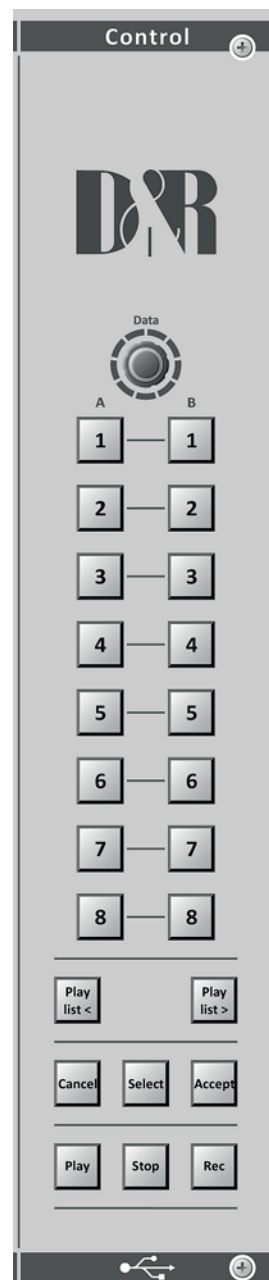

Figure 1. Airlab Control Module

16. USB channel controls

Furthermore, the faderstart, on and cue signals of the four available USB channels in the Airlab mixer could also be used to trigger or control any software application. In combination with the control module the Airlab mixer provides a flexible all-in-one solution to manage and control specific playout systems.

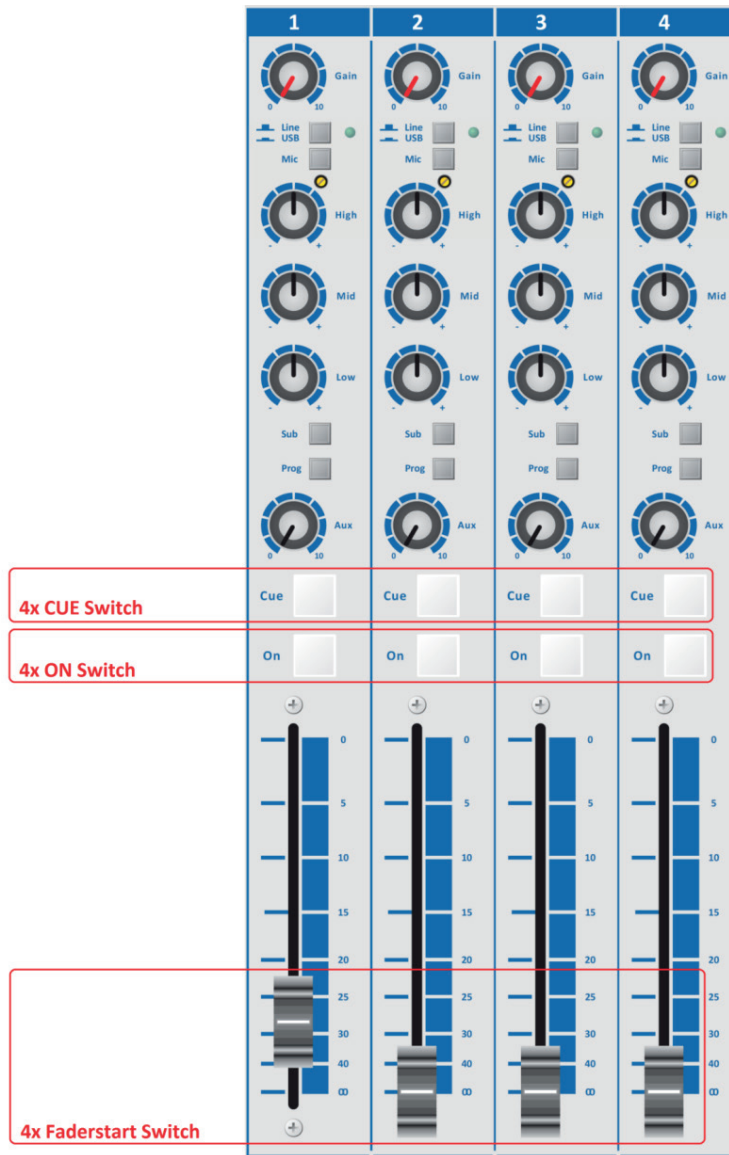

Figure 2. USB Channel Controls

How does it work?

Communication Interface

The present USB bus on the Airlab mixer is used as the interface to transfer all the control signals to the PC. In order to keep things simple the HID (Human Interface Device) protocol is used for communication between the Airlab mixer and PC. On top of the HID protocol there is specific control protocol developed at D&R which is discussed in depth in the chapter "Airlab USB HID Control Protocol".

Update rate

When a state change of a control signal (switch, fader, encoder) occurs, the current state of all the controls are transmitted to the PC. Such a state change of a control signal is called an event. The state of a switch can hold *pressed* or *released*. In case of an encoder the additional states besides the *pressed* and *released* when pushing the encoder (switch function), are *increment* or *decrement* when turning.

17. Controlling your software application

In order to be able to control a software application (i.e. playout software) with the Airlab control signals (control module / USB channel controls), one can choose one of the two available methodologies as can be seen in the figure below.

The first method is most applicable for the software developers of the controlled application, who are able to integrate the Airlab USB HID Control Protocol in their application. For more information about the protocol refer to the Airlab USB HID Control Protocol chapter further in this document.

The second method uses a 'mapper-application' in between the HID messages and the controlled application and is created for the end user. The Virtual Keyboard Mapper maps the control signals coming from the Airlab mixer to standard keyboard keystrokes.

In such a way pressing a switch on the control module will lead to a customizable keystroke which controls a specific function inside the controlled application (playout software) for example.

- Method 1 (developer):
 - Direct access to control messages
 - Full duplex: read control signals / control LED's behind switches
 - Programming is necessary to integrate the protocol in the application
- Method 2 (end user):
 - Easy to use (No programming for integration in application needed)
 - Half duplex: read control signals
 - Quick started using the Virtual Keyboard Mapper features

AIRLAB-DT uses the same protocol as our AIRENCE mixers

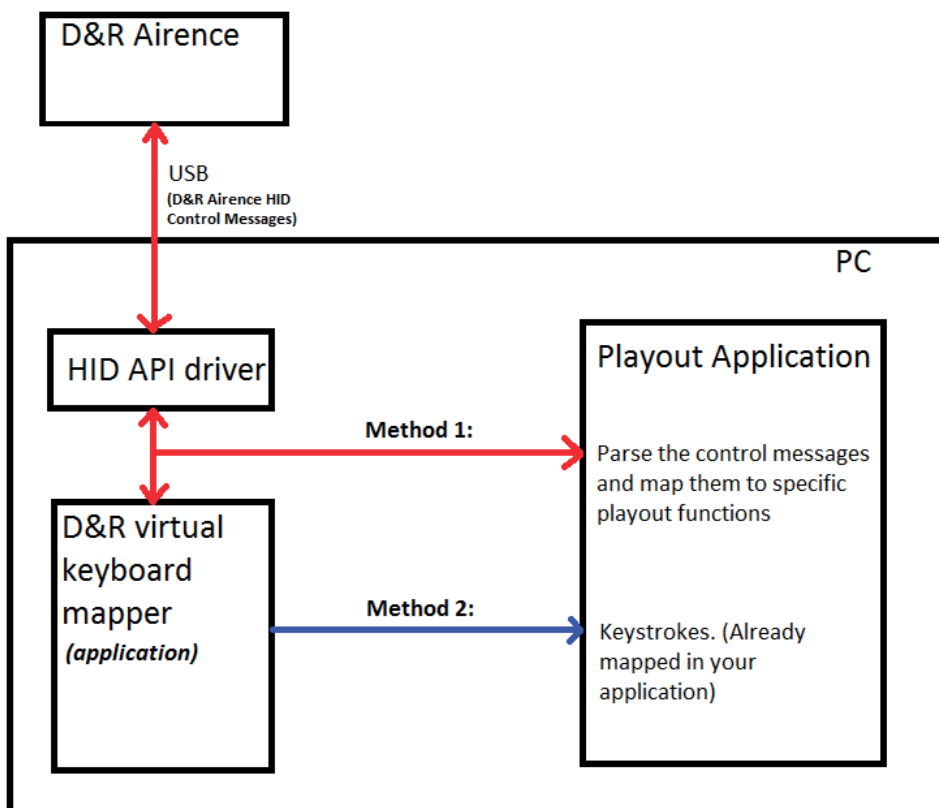

Figure 3. Airlab(Airence) control methodologies

18. Airlab virtual keyboard mapper

The Airlab virtual keyboard mapper is a software application which maps incoming control signals from the Airlab mixer to keystrokes by creating a virtual keyboard on a windows machine. Since the mapper application behaves like a real keyboard it is able to control any software application which is controllable by a keyboard. Most software applications have attached keystrokes to filemenu items or application specific functions. All the incoming control signals from the Airlab mixer can be individually mapped to such predefined keystrokes.

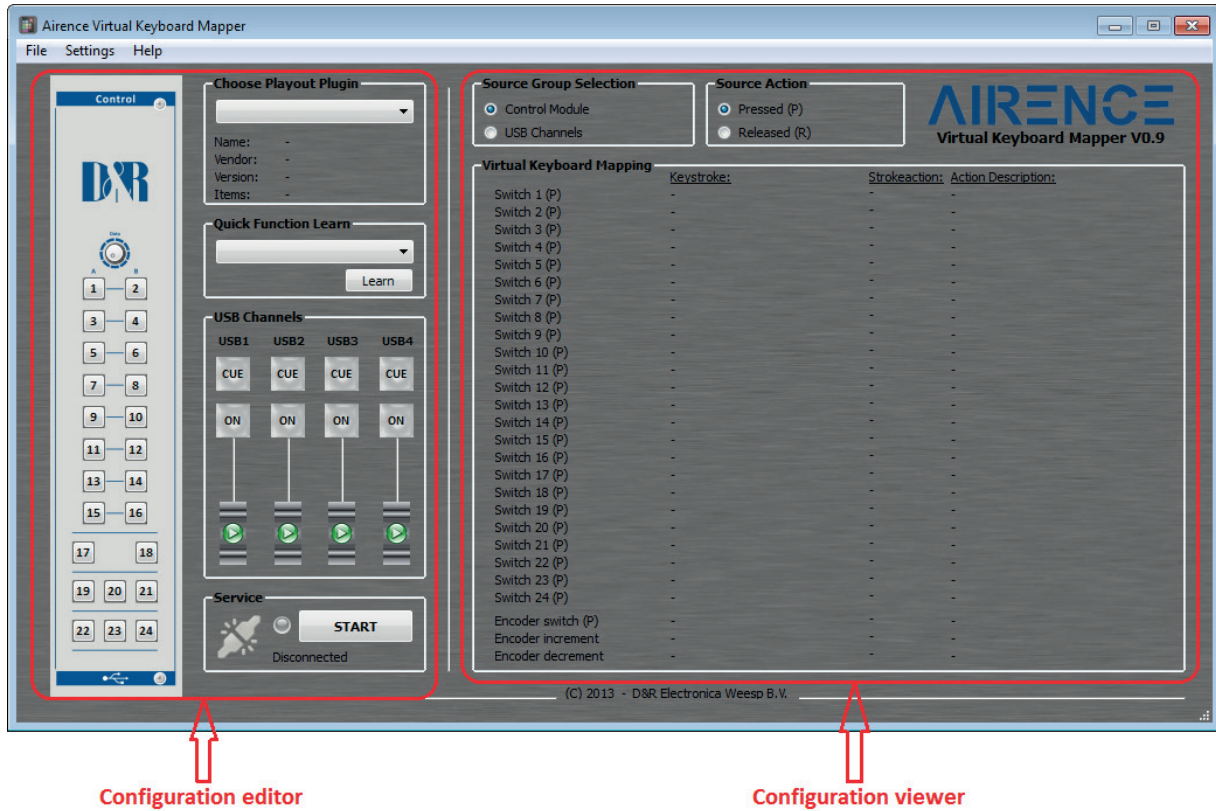

Figure 4. Airlab/Airence virtual keyboard mapper, Windows-based application

Control signals

In total there are 39 control signals coming from the Airlab mixer which can be mapped to keystrokes using the Airlab virtual keyboard mapper application. These 39 control signals are divided into the Control Module signals and USB Channel controls.

Control Module:

- ✓ Switches 1..24
- ✓ Encoder switch
- ✓ Encoder increment
- ✓ Encoder decrement

USB Channel Controls:

- ✓ Cue (4x)
- ✓ On (4x)
- ✓ Faderstart (4x)

Each control signal may generate a *press* or *release* event (except the encoder) which can in turn trigger two separate keystrokes. Especially for the USB Channel Controls (latching switches) it can be useful to control two functions when pressing(P) or releasing(R) the switch. For example:

USB1 ON (P) □Ctrl+Alt+F1 (function X in controlled application)

USB1 ON (R) □Ctrl+Alt+F2 (function Y in controlled application)

19. Setting up your configuration

The Airlab virtual keyboard mapper application can be split up in a *configuration editor* and *configuration viewer* section as can be seen in the figure above. In the *configuration editor* section one is able to attach keystrokes to the control signals. To do so, clicking on one of the switches, encoder or faders opens up a *keystroke configuration editor* window where the configuration of the relevant control signal can be done. Configuring another control signal can be achieved by selecting one from the **Source Select** selection box, or by clicking on the relevant control signal on the main window.

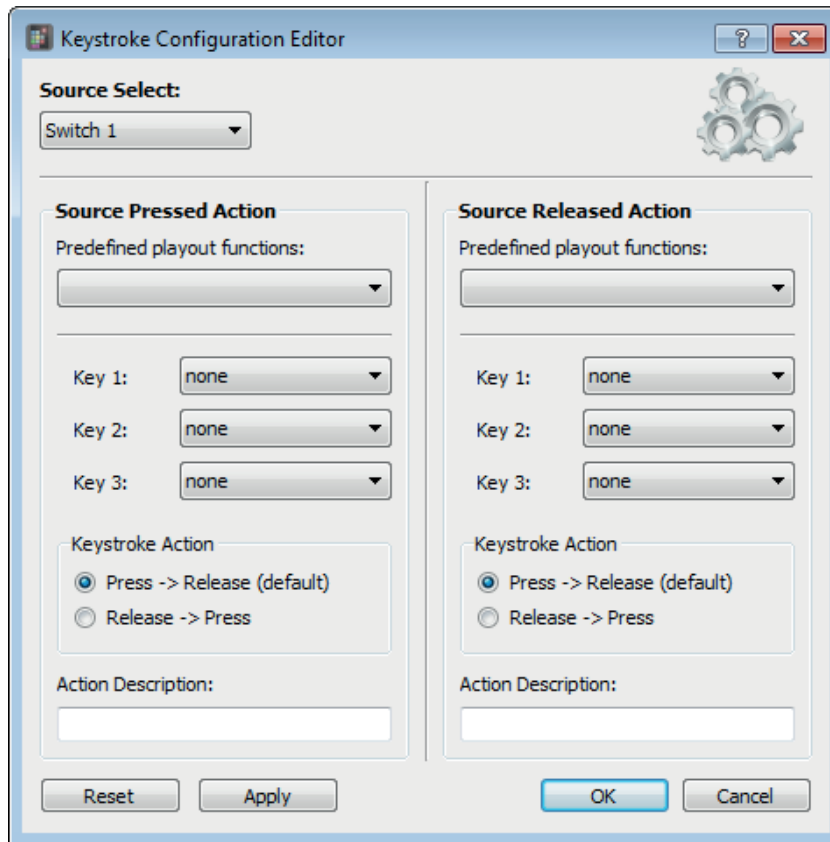

Figure 5. Editor window for mapping control signals to keystrokes

Source Select

At the top of this window one can see a selection box where the control signals are listed under **Source Select**. When clicking on one of the control signals at the main window the *Keystroke configuration editor* automatically selects this control signal (source) in the selection box. All settings in this window have regard to the selected source.

Source Action

In the two action field groups the *press* and *release* events of a control signal can be configured. If there is a playout plugin selected at the main window one can choose from predefined functions of that specific playout software. When selecting one of those functions the remaining fields will be filled in automatically. In such a way one don't has to worry about the keystroke and rather can focus on mapping a control signal to a playout function. However, making some manual changes in the settings after selecting a predefined playout function is always possible.

When no playout plugin is selected one is not able to select a playout function from the list and is therefore required to fill in the fields manually. A maximum of three keys can be configured to construct a keystroke. Start with configuring *Key 1* upwards if more than one key is included in the keystroke. The keystroke action can be inverted if required. Finally there is a field to give the action a meaningful name. The reset button resets entire configuration for the selected source. The settings will be applied when pressing the apply button.

Playout plugins

An playout plugin is a set of function descriptions of a specific software application (playout software) which are mapped to keystrokes. A plugin is represented as a standard XML-file which can be seen in the figure below. There is a plugin folder *PLUGINS* created in the installation directory during setup where the plugins are located or has to be placed when creating one. Present plugins in this folder are loaded when *Virtual Keyboard Mapper* is starting up.

The advantage of using plugins will be the ease of mapping a control signal to a function. One don't needs to worry about the underlying keystroke of a relevant function since selecting a function from the *Keystroke Configuration Editor* will fill in the corresponding keystroke automatically. These keystrokes are fetched from the plugin file.

```

1 <?xml version="1.0" encoding="UTF-8"?>
2
3 <airenceplugin>
4   <name>PC Radio 6</name>
5   <vendor>Broadcast Partners</vendor>
6   <version>6.3.8.15</version>
7   <nfunctions>2</nfunctions>
8
9   <function id="1">
10     <description>Jingle Player 1</description>
11     <keystroke>
12       <key1>3</key1>
13       <key2>4</key2>
14       <key3>26</key3>
15     </keystroke>
16   </function>
17   <function id="2">
18     <description>Jingle Player 2</description>
19     <keystroke>
20       <key1>3</key1>
21       <key2>4</key2>
22       <key3>27</key3>
23     </keystroke>
24   </function>
25 </airenceplugin>

```

Plugin information

Keystroke
3 - Left Ctrl
4 - Left Alt
26 - F1

Figure 6. Example of playout plugin file

20. Create a plugin

A plugin is specific for each playout software. If the used playout software is not available as a plugin one needs to create the plugin yourself. Since the plugins are represented in the XML format (which is readable for machine as well as human) it is not that hard to create one. It is advisable to use another plugin as template and adjust that file. In the above figure a basic example plugin file is shown with two functions. If more functions are needed simple copy and paste a function block (line 9 – 16).

The plugin starts always with a block of plugin information (name, vendor, version, nfunctions). The function element contains the number of functions which are included in the plugin. After the plugin information the functions are listed beneath each other. In the description field the name of the function needs to be filled in. This name will be used later on in the *Keystroke Configuration Editor* to choose a function from the list.

Finally, there is a keystroke element which contains three other elements *key1*, *key2*, and *key3* respectively. These last three elements contain together the keystroke to perform when the function needs to be executed. A keystroke can consist of maximum three keys. Each key element can be filled with a ID key value between 0 and 91. The ID value represent a key on the keyboard which can be found in the table in the figure below.

ID:	Name:	ID:	Name:	ID:	Name:	ID:	Name:
0	none	23	Delete	46	Key_8	69	Key_S
1	Esc	24	Page Up	47	Key_9	70	Key_T
2	Tab	25	Page Down	48	-	71	Key_U
3	Left Ctrl	26	F1	49	+	72	Key_V
4	Left Alt	27	F2	50	Backspace	73	Key_W
5	Left Shift	28	F3	51	Key_A	74	Key_X
6	Left Win	29	F4	52	Key_B	75	Key_Y
7	Right Ctrl	30	F5	53	Key_C	76	Key_Z
8	Right Alt	31	F6	54	Key_D	77	Numpad 0
9	Right Shift	32	F7	55	Key_E	78	Numpad 1
10	Right Win	33	F8	56	Key_F	79	Numpad 2
11	Space	34	F9	57	Key_G	80	Numpad 3
12	Enter	35	F10	58	Key_H	81	Numpad 4
13	Arrow Left	36	F11	59	Key_I	82	Numpad 5
14	Arrow Right	37	F12	60	Key_J	83	Numpad 6
15	Arrow Up	38	Key_0	61	Key_K	84	Numpad 7
16	Arrow Down	39	Key_1	62	Key_L	85	Numpad 8
17	Scroll Lock	40	Key_2	63	Key_M	86	Numpad 9
18	Print Screen	41	Key_3	64	Key_N	87	Numpad /
19	Insert	42	Key_4	65	Key_O	88	Numpad *
20	Pause/Break	43	Key_5	66	Key_P	89	Numpad -
21	Home	44	Key_6	67	Key_Q	90	Numpad +
22	End	45	Key_7	68	Key_R	91	Numpad .

Figure 7. Keyboard keys vs. ID

21. Quick function Learn

The Quick Function Learn is a feature to map control signals to playout functions rapidly. First one has to select a playout plugin before the quick function learn can be used. If the playout plugin is loaded correctly, the contained functions are listed in the *Quick Function Learn* box.

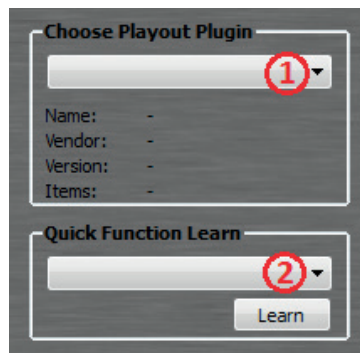

Figure 8. Playout plugin required for using the Quick Function Learn

Select one of the available functions from the *Quick Function Learn* box and press the *Learn* button. The window as seen in the figure below will show up and waits for a control signal event coming from the Airlab mixer. If a control signal is received the selected function is immediately mapped to this control signal.

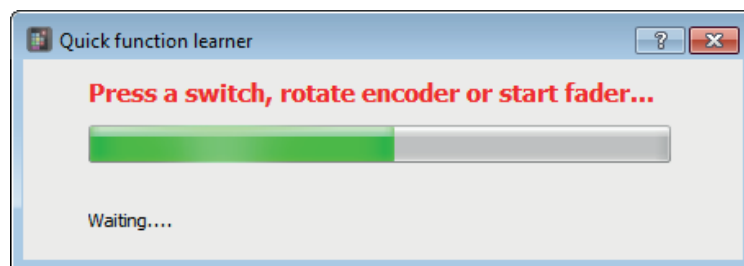

Figure 9. Quick function learner waiting for response

22. Configuration viewer

In the *configuration viewer* section an overview of the entire configuration can be seen. All the pressed and released events of the control signals are shown in the *Virtual Keyboard Mapping* area. In order to get a clear overview the view section is divided into four pages:

- ✓ Control Module (Pressed)
- ✓ Control Module (Released)
- ✓ USB Channels (Pressed)
- ✓ USB Channels (Released)

Selecting one of the four pages is done by the radio buttons in the *Source Group Selection* and *Source Action* boxes which are located above the *configuration viewer* section.

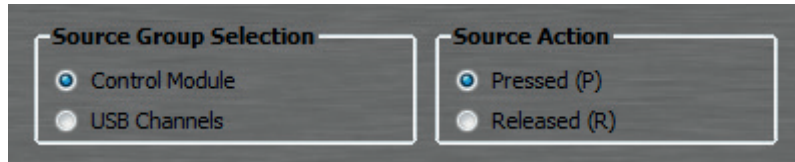

Figure 10. Page selection view

Let's get connected

When done with setting up the configuration the Virtual Keyboard Mapper application is ready to receive changes of the control signals from the Airlab mixer. To do so, one has to press the *START* button in the Service box. If the application is able to connect to the Airlab mixer the label on the button would change into *STOP* and the firmware revision of the mixer is shown. The indicator near the button indicates incoming messages. Pressing the *STOP* button will stop the service and disconnect the Airence mixer.

When a control signal is received and is mapped to a keystroke, this keystroke will be executed in real time. To let the executed keystroke trigger a function in a software application one has to take care of giving this application focus. An application is only be able to receive input when it currently has the focus.

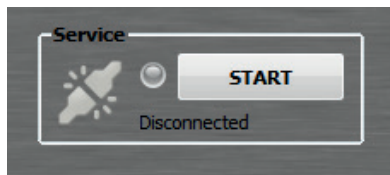

Figure 7a. Disconnected

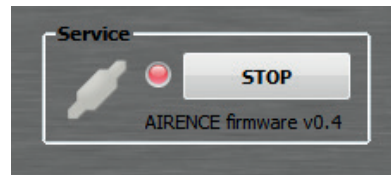

Figure 7b. Connected

Presets

A preset is a backup of the entire configuration of the control signals with their mapped keystrokes. Presets can be useful when one wants to recall or store a complete configuration for specific playout software. Presets are represented as *.akp* files (Airlab Keyboard Preset).

Store preset

Storing the current configuration as a preset can be done by clicking on *File->Save*, or *File->Save as*.

Recall preset

Recalling a stored preset can be done by clicking on *File->Open* and selecting the desired preset.

Settings

Under *Settings->Presets* one can find the preset settings. A configuration window is shown whereby the default preset directory and the startup preset can be configured.

23. Airlab USB HID Control Protocol

Introduction

This chapter describes the protocol which is used to communicate with the control section and the USB channel controls of the Airence mixer. For the communication between the PC (host) and Airlab (device) the USB generic HID (Human Interface Device) class protocol is used. HID devices are identified by their PID and VID. For the Airlab the **PID=0x2402**, and the **VID=0x03EB**. On top of the HID protocol, a custom message based protocol provides the commands to send and receive data which will be described in more detail in this chapter.

Message format

Transmitting data through the USB bus using the HID class protocol is done by reports. A report always contains an ID and the data inside the report. In order to successfully communicate with the Airlab control section **only reportID 0** may be used. More information about report descriptors can be found on www.usb.org. For now, remember that the Airence only will listen to reports with reportID = 0.

A control message has a fixed size of 8 bytes containing a *SIZE* byte, *COMMAND* byte, and a *PAYLOAD* section of maximal 6 bytes. The *SIZE* byte contains the number of bytes used (max. 8) in the message, including this *SIZE* byte.

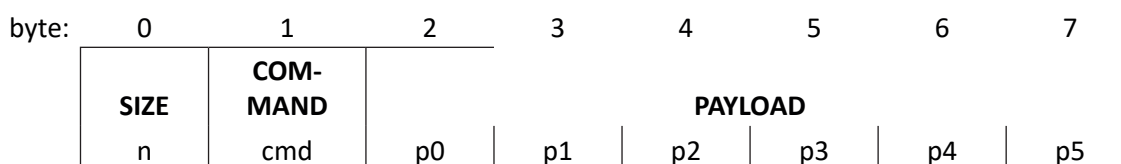

Command byte

The command byte consists of a 2-bit *TYPE* and a 6-bit *ID* field.

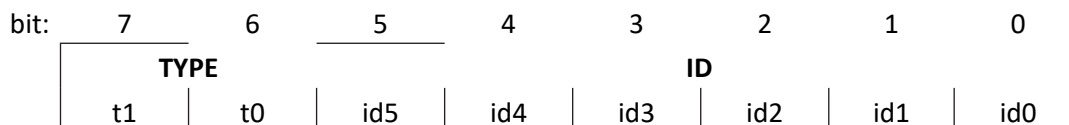

Bit	Symbol	Value	Description
5:0	ID	-	Command Identifier (ID)
7:6	TYPE	00	Write command, from host to device
		01	Request command, from host to device
		10	Response command, reply from device to host on a request
		11	Event, from device to host (i.e. button pressed)

Command ID

A commandID can have a value between 0x01 and 0x3F. The following commandIDs are currently available in the Airlab:

Value	Description
0x01	AIRLAB_FIRMWARE_VERSION
0x02	AIRLAB_LED
0x03	AIRLAB_LED_BLINK
0x04	-
0x05	AIRLAB_SWITCH_CHANGE
0x06	AIRLAB_ENCODER_INCREMENT
0x07	AIRLAB_ENCODER_DECREMENT

Messages

Write

A message of the type *WRITE* is transmitted from the PC to Airlab. The message is intended to perform an action on the Airlab control section (i.e. illuminate a LED). If the action is correctly executed, the Airlab will reply with a corresponding event.

AIRLAB-DT_LED_WRITE

byte:	0	1	2	3	4	5	6	7
	SIZE	COM- MAND	PAYLOAD					
	0x04	0x02	lednum	color	-	-	-	-

Byte	Symbol	Value	Description
0	SIZE	0x04	Message size
1	COMMAND	0x02	AIRLAB_LED_WRITE
2	lednum		LED number, 1(0x01) to 24(0x18), 0xFF = ALL LEDs
3	color	0x00	NONE (LED off)
		0x01	RED
		0x02	GREEN
		0x03	YELLOW

AIRLAB-DT_LED_BLINK_WRITE

byte:	0	1	2	3	4	5	6	7
	SIZE	COM- MAND	PAYLOAD					
	0x06	0x03	lednum	color_on	color_off	speed	-	-

Byte	Symbol	Value	Description
0	SIZE	0x06	Message size
1	COMMAND	0x03	AIRLAB_LED_BLINK_WRITE
2	lednum		LED number, 1(0x01) to 24(0x18), 0xFF = ALL LEDs
3	color_on	0x00	NONE (LED off)
		0x01	RED
		0x02	GREEN
		0x03	YELLOW
4	color_off	0x00	NONE (LED off)
		0x01	RED
		0x02	GREEN
		0x03	YELLOW
5	speed	0x00	SLOW
		0x01	NORMAL
		0x02	FAST

Request

A message of the type *REQUEST* is transmitted from the PC to Airlab. The message is intended to read data from the Airlab. After the Airlab received the request it will respond with a corresponding *RESPONSE* message. Therefore, a *REQUEST* message always forms a pair with a *RESPONSE* message.

AIRLAB-DT_FIRMWARE_VERSION_REQUEST

byte:	0	1	2	3	4	5	6	7
	SIZE	COM-MAND	PAYLOAD					
	0x02	0x41	-	-	-	-	-	-

Byte	Symbol	Value	Description
0	SIZE	0x02	Message size
1	COMMAND	0x41	AIRLAB_FIRMWARE_VERSION_REQUEST

Response

A message of the type *RESPONSE* is transmitted from the Airlab to the PC when prior a firmware version request message was received.

AIRLAB-DT_FIRMWARE_VERSION_RESPONSE

byte:	0	1	2	3	4	5	6	7
	SIZE	COM-MAND	PAYLOAD					
	0x04	0x81	major	minor	-	-	-	-

Byte	Symbol	Value	Description
0	SIZE	0x04	Message size
1	COMMAND	0x81	AIRLAB_FIRMWARE_VERSION_RESPONSE
2	major		Firmware major revision
3	minor		Firmware minor revision

Events

A message of the type *EVENT* is transmitted from the Airlab-DT to the PC. An event will be generated when the state of a switch, encoder, or LED has changed. These events can be used to synchronize states of LEDs and switches between the Aircore and the controlled application on the PC.

AIRLAB_LED_EVENT

byte:	0	1	2	3	4	5	6	7
	SIZE	COM-MAND	PAYLOAD					
	0x04	0xC2	lednum	color	-	-	-	-

Byte	Symbol	Value	Description
0	SIZE	0x04	Message size
1	COMMAND	0xC2	AIRLAB_LED_EVENT
2	lednum		LED number, 1(0x01) to 24(0x18), 0xFF = ALL LEDs
3	color	0x00	NONE (LED off)
		0x01	RED
		0x02	GREEN
		0x03	YELLOW

AIRLAB-DT_LED_BLINK_EVENT

byte:	0	1	2	3	4	5	6	7
	SIZE	COM-MAND	PAYLOAD					
	0x06	0xC3	lednum	color_on	color_off	speed	-	-

Byte	Symbol	Value	Description
0	SIZE	0x06	Message size
1	COMMAND	0xC3	AIRENCE_LED_BLINK_EVENT
2	lednum		LED number, 1(0x01) to 24(0x18), 0xFF = ALL LEDs
3	color_on	0x00	NONE (LED off)
		0x01	RED
		0x02	GREEN
		0x03	YELLOW
4	color_off	0x00	NONE (LED off)
		0x01	RED
		0x02	GREEN
		0x03	YELLOW
5	speed	0x00	SLOW
		0x01	NORMAL
		0x02	FAST

AIRLAB-DT_SWITCH_CHANGE_EVENT

byte:	0	1	2	3	4	5	6	7
	SIZE	COM-MAND	PAYLOAD					
	0x06	0xC5	sw_8_1	sw_16_9		sw_enc_non	usb_2_1	usb_4_3

Byte	Symbol	Value	Description
0	SIZE	0x06	Message size
1	COMMAND	0xC5	AIRENCE_SWITCH_CHANGE_EVENT
4:2	sw_m_n	-	bit 0: switch n (1=pressed, 0=released) bit 7: switch m
5	sw_enc_non	-	bit 0: encoder switch (1=pressed, 0=released) bit 1: non-stop switch (1=pressed, 0=released)
6	usb_2_1	-	bit 0: USB1 faderstart (1=ON, 0=OFF)
			bit 1: USB1 ON (1=pressed, 0=released)
			bit 2: USB1 CUE (1=pressed, 0=released)
			bit 3: USB2 faderstart (1=ON, 0=OFF)
			bit 4: USB2 ON (1=pressed, 0=released)
			bit 5: USB2 CUE (1=pressed, 0=released)
7	usb_4_3	-	bit 0: USB3 faderstart (1=ON, 0=OFF)
			bit 1: USB3 ON (1=pressed, 0=released)
			bit 2: USB3 CUE (1=pressed, 0=released)
			bit 3: USB4 faderstart (1=ON, 0=OFF)
			bit 4: USB4 ON (1=pressed, 0=released)
			bit 5: USB4 CUE (1=pressed, 0=released)

AIRLAB-DT_ENCODER_INCREMENT_EVENT

```

-----
byte:  0          1          2          3          4          5          6          7
SIZE   COMMAND    PAYLOAD
0x03   0xC6       abs_value  -        -        -        -        -
    
```

```

=====
Byte   Symbol      Value      Description
0      SIZE         0x03      Message size
1      COMMAND      0xC6      AIRENCE_ENCODER_INCREMENT_EVENT
2      abs_value     Absolute encoder value [ 0 - 255 ] (wrap around)
    
```

AIRENCE_ENCODER_DECREMENT_EVENT

```

-----
byte:  0          1          2          3          4          5          6          7
SIZE   COMMAND    PAYLOAD
0x03   0xC7       abs_value  -        -        -        -        -
    
```

```

=====
Byte   Symbol      Value  D  escription
0      SIZE         0x03  M  Message size
1      COMMAND      0xC7  A  AIRENCE_ENCODER_DECREMENT_EVENT
2      abs_value     Absolute encoder value [ 0 - 255 ] (wrap around)
    
```

=====

The mains input accepts 100volt to 230 volt 50/60 Hz.

=====

EXTERN IN/AIR IN

The next section shows the left and right input Cinch connectors for the EXTERNAL and AIR in signals. FROM AIR is the stereo input for controlling the off air signal coming from a receiver. Input sensitivity is either 0 dBu.

GUEST/ANNOUNCER

The next connectors on the right are the stereo GUEST and ANNOUNCER headphone outputs on stereo jack sockets.

ON AIR 1/2

On the left side of these jacks are the ON-AIR 1 and ON-AIR 2 jacks. The ON-AIR signaling jacks are connected to reed relays driven by the logic of the input channels as described in the channel sections of this manual.

When using the channel in the DJ mode it is possible to operate and be an ANNOUNCER at the same time.

If the DJ mic is ON or CUE'd, the CRM is automatically muted.

Modules can be connected via programming to the centralized ON-AIR signaling connector.

We advise to use the D&R ON-AIR Led light that does not need any extra electronics to function on these jack connectors.

In case you still want a high power ON-AIR light driven by 115/230 volts we advise you to use an externally connected solid-state relay. A suitable model is the S 201-8 04 from Sharp, which switches 230 Volts/1.5 Amp click-free. A solid-state relay is much safer to use and is more reliable. The ON-AIR 1/2 output can be connected directly to the S 201-8 04 relay in series with an external 12-volt DC power supply.

Connector:	Tip	=	Center contact
(maximum 24V/50mA)	Ring	=	Normally open
	Sleeve	=	Normally closed

NOTE: These signaling outputs are only to be used for low voltage applications!

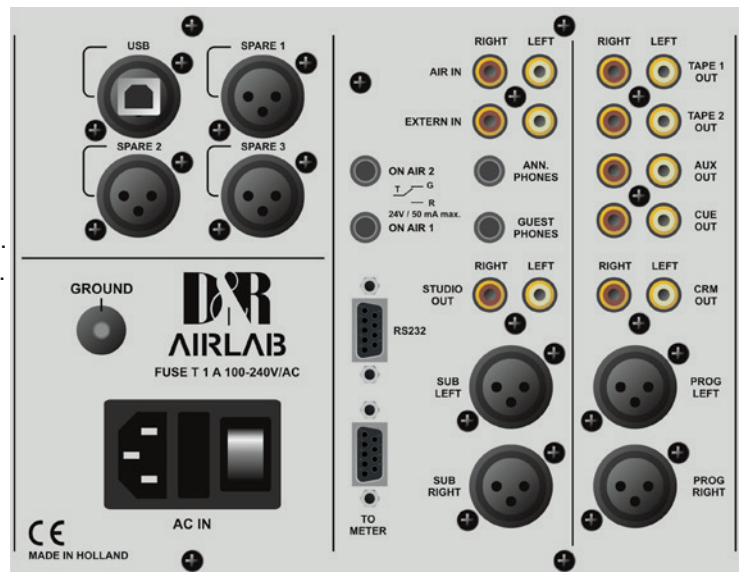

Figure 3: The connections on the Master Section

STUDIO

The two Cinch connectors are the unbalanced Studio outputs. The level is +6 dBu at 47 Ohm.

SUB OUTPUTS

These outputs are electronically balanced and wired to male XLR outputs.

Output level is +6 dBu at 47 Ohm.

(Transformers are optional)

RS232

This computer type connector is the interface between the Airlab and a PC. Through this connector and the delivered software it is possible to program the Airlab on your PC.

This special cable is part of the delivery and also sends the meter signals to the meter application.

Chapter 14 will give you detailed information about this programming.

TO METER

This SubD9 connector provides power and signals to an external hardware meters if present.

MORE OUTPUTS

In this section of the master back panel you find the following output connectors.

Tape-1 out stereo, Tape-2 out stereo, AUX. out stereo, CUE out stereo, CRM out stereo and PROGRAM left/right.

PROGRAM OUTPUTS

The Airlab contains two electronically balanced outputs that can be transformer balanced as an option. Both outputs shall have their own line output amps with high quality output transformers as an option. The output level is +6 dB at 600 Ohm when the meter reads 0 dB.

Connectors are XLR male: Pin 1 = ground
Pin 2 = in phase
Pin 3 = out of phase

If the Airlab is required to drive unbalanced equipment, Pins 1 and 3 must be shorted.

Spare-1 is a digital AES Program output

Spare-2 is a digital AES Sub Output

(only if 2 digital input modules are installed)

In case only one digital module is installed a jumper selects Program or Sub for Spare-1

PHONES OUTPUT

The engineer's stereo headphone output shall also be used as DJ output.

NOTE: DO NOT use headphones with an impedance lower than 200 Ohm. 600 Ohm is preferable. The jack is positioned on your right hand side in front side of the frame.

Connector type is stereo jack plug: Tip = left
Ring = right
Sleeve = ground

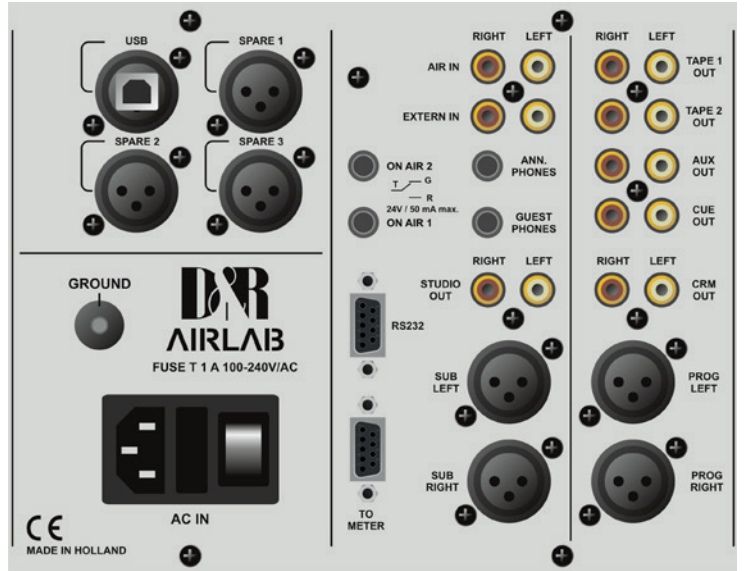

24. AIRLAB MASTER BACK PANEL WIRING

EXTERN IN

Connector type is Cinch. Unbalanced, level = 0 dBu 10 kOhm

AIR IN

Connector type is Cinch. Unbalanced, level = 0 dBu 10 kOhm

GUEST OUT STEREO

Connector type: Jack Tip = Left
Level: +20 dBu/330 Ohm Ring = Right
Sleeve = Ground

ANNOUNCER OUT STEREO

Connector type: Jack Tip = Left
Level: +20 dBu/330 Ohm Ring = Right
Sleeve = Ground

ON AIR SIGNALING 1

Connector type: Jack REED RELAY MAX VOLTAGE 24 VOLT/50 mA
Tip = Center contact
Ring = Normally open
Sleeve = Normally closed

ON AIR SIGNALING 2

Connector type: Jack REED RELAY MAX VOLTAGE 24 VOLT/50 mA
Tip = Center contact
Ring = Normally open
Sleeve = Normally close

STUDIO OUT

Connector type: Cinch, Unbalanced
Level: +6dBu / 47 Ohm

SUB OUTPUTS

Connector type: Male XLR
Level: +6dBu
Pin1 = ground
Pin2 = in phase
Pin3 = out of phase

RS 232

Connector type: SubD9 Male
1 = CD (Doesn't need to be connected)*
2 = TD
3 = RD
4 = DTR (Doesn't need to be connected)*
5 = gnd
6 = DSR (Doesn't need to be connected)*
7 = RTS (Doesn't need to be connected)*
8 = CTS (Doesn't need to be connected)*
9 = NC
* (Some PC's require connection instead)

METER

Connector type: SubD9 Female
1 = CRM-right (feeds meter right)
2 = ground
3 = External CUE LED drive
4 = ground
5 = Program right signal
6 = CRM left signal
7 = +18 volt
8 = -18 volt
9 = Program left signal

TAPE 1 OUT STEREO

Connector type: Cinch
Level: 0 dBu/100 Ohm

TAPE 2 OUT STEREO

Connector type: Cinch
Level: 0 dBu/100 Ohm

AUX OUT STEREO

Connector type: Cinch
Level: +6 dBu/100 Ohm

CUE OUT STEREO

Connector type: Cinch
Level: +6 dBu/100 Ohm

CRM OUT STEREO

Connector type: Cinch
Level: +6 dBu/100 Ohm

PROGRAM OUTPUTS

Connector type: Male XLR
Level is: +6 dBu
Pin 1 = ground
Pin 2 = in phase
Pin 3 = out of phase

PHONES OUT STEREO

Connector type: Jack
Level: +20dBu/330 Ohm
Tip = Left
Ring = Right
Sleeve = Ground

25. METER INSTALLING/CONFIGURATION

On the USB stick that is part of the delivery there are 2 files:

1. Airlab Meters v1.7 - Setup.exe
2. Airlab Control Center v3.1 - Setup.exe

Please install the Airlab Meters v1.7 - Setup.exe first.

After installation you will see the meter application as shown on the right side.



Pressing the settings button (on the right hand top of the application skin opens up the Communication Interface window.

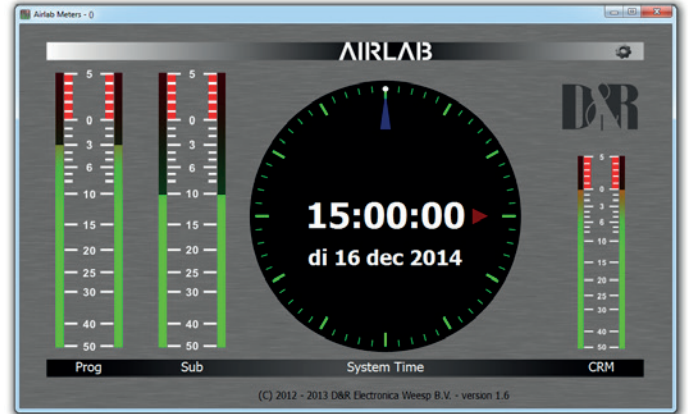

In the Communication Interface window one can select the correct virtual serial port which will be created when the Airence mixer is connected to the PC with a USB cable. Select the serial port from the drop down menu with 'USB Serial Port' in the name. This is the port where the metering data is received from the mixer.

The meter application has an additional Server/Client feature which can be used to forward metering data over a LAN network. In such a way another PC within the same network is able to fetch the data from the network and show it in its own meter application.

Server: This is the application where the Airlab-DT physically is connected to with a USB cable. Select the appropriate server IP address and port to forward the metering data to.

Client: This is the receiving application. Setup the server host IP address and port in the corresponding fields.

Server mode

Client mode

26. AIRLAB-DT JUMPER SETTINGS

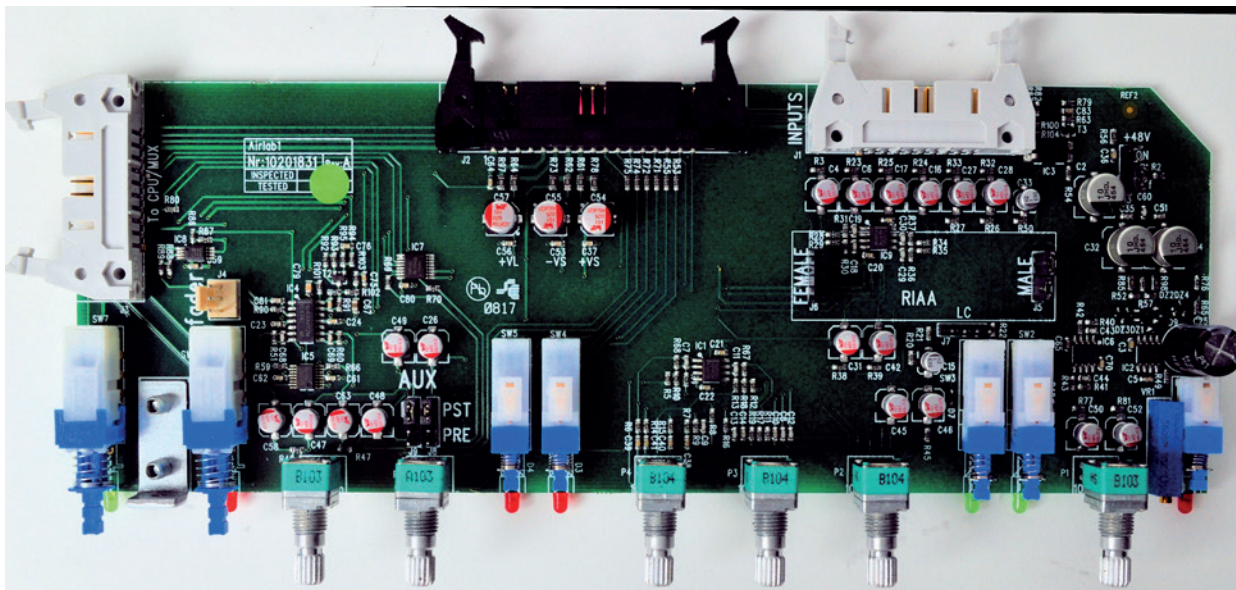

Options	Jumpers	Settings	Settings	Default
AUX PRE/POST	J8 and J9	1 + 2 = POST	3 + 4 = PRE	POST
LC MIC only	J7	1+2 / 3+4 = ON	No Jumper = OFF	OFF
48 volt Phantom	J13	1 + 2 = OFF	3 + 4 = ON	OFF
EQ/ON/OFF	J11 and J12	1 + 2 / 3+4 = ON	2+3 / 3 + 4 = OFF	ON

Table 1: AirLab-DT Triple Module Jumper settings

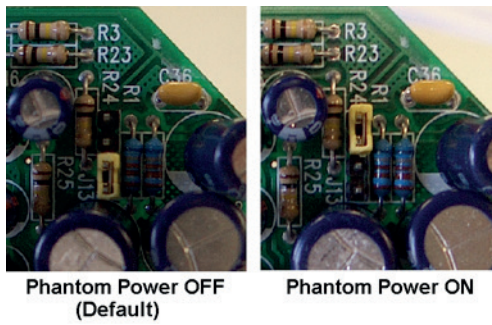

Figure 7: Triple Module Phantom Power Jumper settings

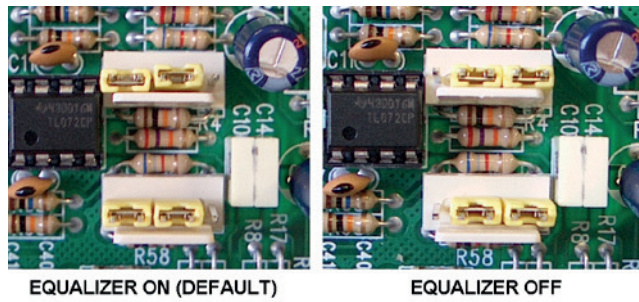

Figure 8: Triple Module EQ Jumper settings

NOTE: An optional R.I.A.A. phono pre amp can be plugged in here. The 'B' input of the channel can thus be connected directly to a phono cartridge. Jumpers should be removed from the channel completely.

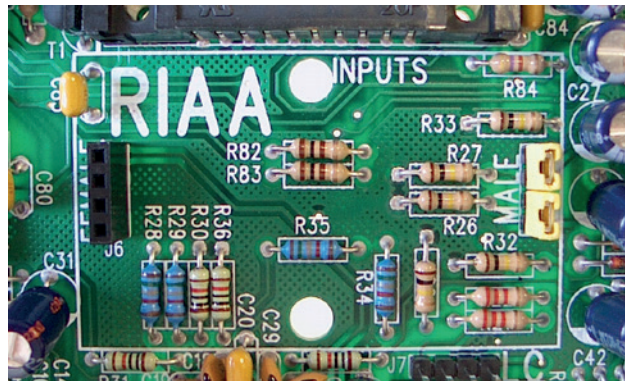

Figure 9: R.I.A.A connection on Triple module

TRIPLE DIG INPUT MODULE

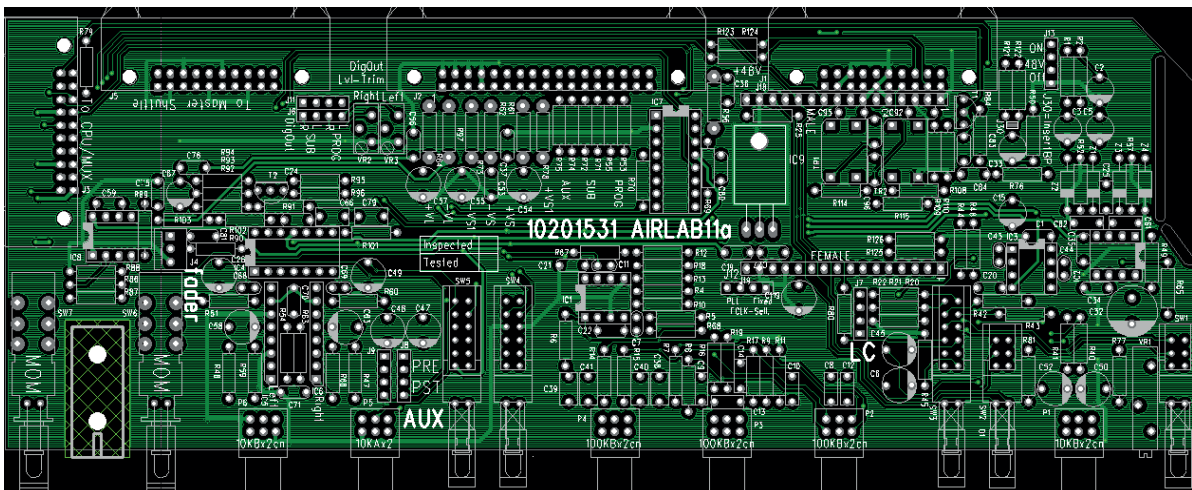

Figure 10: Airlab Triple Dig Module Jumper Locations

Options	Jumpers	Settings	Settings	Default
AUX PRE/POST	J8 and J9	1 + 2 = POST	3 + 4 = PRE	POST
LC MIC only	J7	1+2 / 3+4 = ON	No Jumper = OFF	OFF
48 volt Phantom	J13	1 + 2 = OFF	3 + 4 = ON	OFF
Dig-Output	J11 en J6	1+1 / 2+2 = SUB	3+3 / 4+4 = PROG	Prog
FCLK Select	J12	1 + 2 = Fixed	3 + 4 = PLL	Fixed

Table 2: Airlab Triple Dig Module Jumper settings

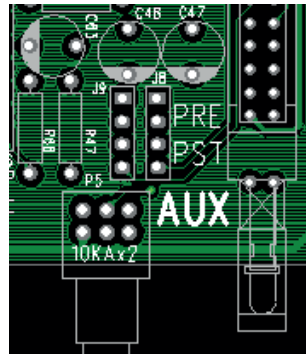

Figure 11: Triple Dig Module AUX Jumper settings

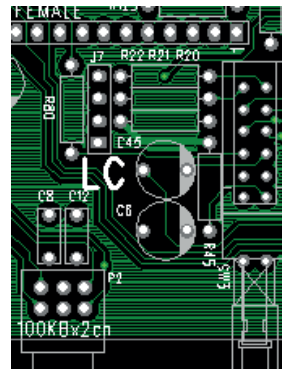

Figure 12: Triple Dig Module MIC LC Jumper settings

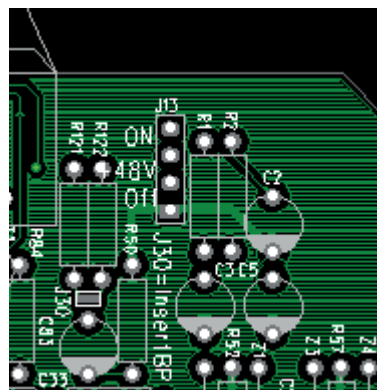

Figure 13: Triple Dig Module Phantom Power Jumper settings

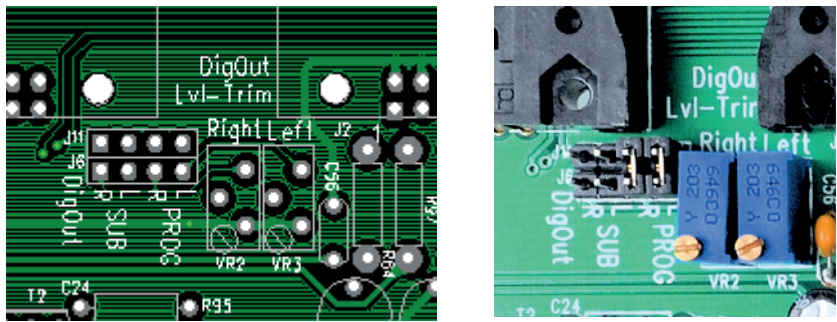

Figure 14: Triple Dig Module Digital Output Select Jumper and Digital Output Level trim

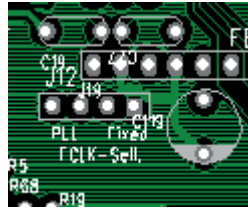

Figure 15: Triple Dig Module FCLK-Select (PLL or Fixed)

Digital Output settings:

Dependent on the jumper setting the output is giving the stereo PROG signal or the stereo SUB-signal. Normally the output level is -9dBFS but the level (headroom) can be adjusted by VR2 and VR3. The digital output frame clock (sample rate) can be setup in two different ways by an internal jumper setting.

- 1: PLL. Output Frame Clock (sample rate) is identical to the clock signal of the digital input (Select by the 'Line B' switch, 32..96 kHz). If the digital-input is not in lock (no input signal or a wrong signal) the Output Frame Clock will jump back to 44.1kHz.
- 2: Fixed. Output Frame Clock (sample rate) is always 44.1kHz

ATTENTION: In the 'PLL' mode the digital output signal will be muted shortly if you change the digital input selection ('Line B' switch) or if the digital input loses its lock.

Digital USB METER 1/2/3 settings:

On the right side you see the AIRLAB-81pcb that shows the possible settings for the 3 software meters. As shown on the picture the selection is made as follows:

- Meter 1 = PROG signal
- Meter 2 = SUB signal
- Meter 3 = CUE signal

There is also the possibility to select AIR (off air) or EXT. (external signals) that enter the consoles master input connectors.

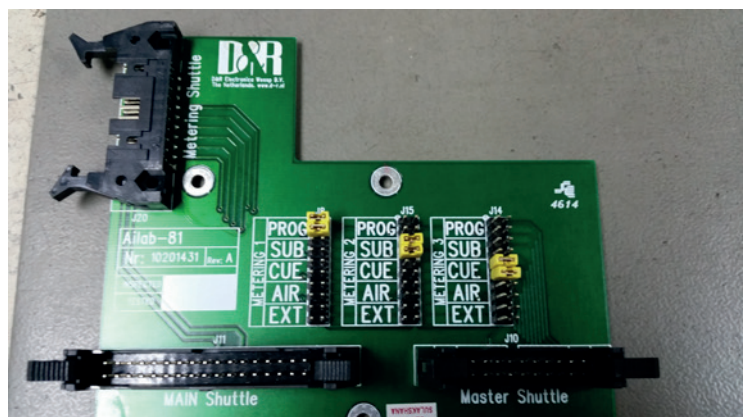

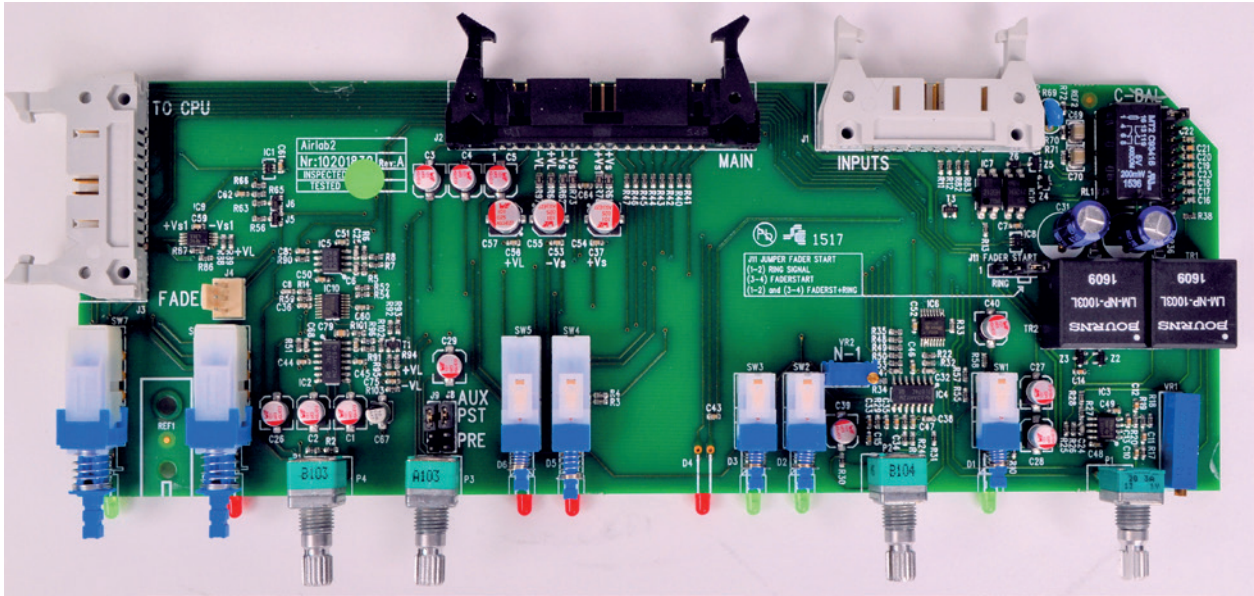

Options	Jumpers	Settings	Settings	Default
AUX PRE/POST	J8 and J9	1 + 2 = POST	3 + 4 = PRE	POST

Table 3: Airlab Telco Module Jumper settings

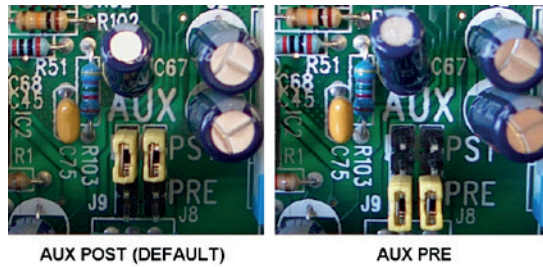

Figure 17: Telco Module AUX Jumper settings

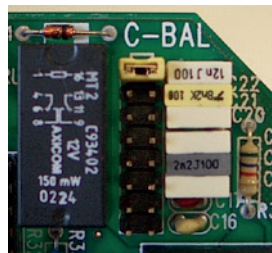

Figure 18: Telco Module C-Balance Setting

OPTIONAL

It's optional to install High quality transformers on the PROGRAM outputs and on the SUB outputs. Please contact your dealer or the factory for further information.

27. INSTALLING/SERVICING THE AIRLAB

Mains

Please check that the local mains supply corresponds with the voltage selected on the Airlab mains inlet.

The Airlab-DT can accept voltages between 90 Volts and 240 Volts.

The Airlab is fused with a 2 Amp slow blow fuse.

DO NOT use any other value, as this would be hazardous and the Airlab guarantee will be voided.

Also do NOT switch the Airlab on and off within 10 seconds. If switched off wait 10 seconds to allow all voltages to drop internally for a clean start.

Clean Power Connection

Be sure to use a 'clean' power outlet, i.e. one that is fed directly from the mains, including earth.

Only connect the Airlab to this outlet and its associated equipment.

This will act as the centralized mains and earth for the studio. It is advisable to install several multiple mains connectors close to the Airlab, with a master power switch to shut down all power to the studio.

Grounding **MUST BE** a star ground system.

Keep all wires as short as possible and never install audio next to power cables.

"Polluted" mains are caused by changing currents on the outlets, such as air-conditioners, coffee machines, fridges, computers, dimmer packs etc. DO NOT connect any of these types of items to the Airlab main power outlet.

Wiring

In cases where all the equipment is transformer balanced, it's usual to connect the shielding of the wiring to the source side only.

In the Airlab, many of the sources will be unbalanced, so a different strategy needs to be adopted.

Equipment, such as CD players, doesn't have a mains ground connection. In this case the shielding can be connected on both sides of the connection. There won't be a ground loop. Try to choose a CD player with metal housing. If you experience problems with the transmitter interfering with the CD sound, connect the CD housing to a ceramic capacitor of 0.01 uF/250 V to the mains earth. Also when wiring the USB cable from the Airlab to the PC be sure that you find the best results when monitoring to avoid digital noise by avoiding groundloops with the PC.

Audio Connections to the Airlab

Prior to commencing wiring of the studio, it is advisable to obtain some labels, which will simplify trouble-shooting.

(Example; "CD-1, CH 2A")

The first step is to connect the Airlab to the mains, with all faders closed, no CRM active and the CRM volume controls fully clockwise.

- A. Connect the CRM amp to the CRM output, and check whether there's any 'hum' or 'noise' noticeable.
- B. Now connect the USB to the PC and check again for 'hum' and 'noise'.
- C. Connect the special RS232 to USB connector the PC and check for additional noise built up.
(when digital noise is detected try to disconnect the PC from ground or use an optical USB isolator .

NOTE: In most cases it is a matter of finding the best grounding for the phono ground by trial and error. This might be directly to the audio ground or to the chassis of the Airlab.

- D. Now connect CD/MD players, and maybe Phono players.

NOTE:

Wiring a tuner needs special attention. If the tuner is "cabled", the coax antenna cable will probably cause a ground loop. A H.F. transformer must separate the antenna input of the tuner. Ask your dealer or any radio shop for details.

IMPORTANT

SAFETY PRECAUTION - All 'outside' connections to the Airlab, even from the same building, must be connected via a transformer. This avoids the possibility of ground loops and 'hums'. The shielding must be connected to the source side. In areas with a strong H.F. interference, it is wise to connect the other side of the shielding through a 0.1 uF/250 Volt ceramic capacitor. The capacitor will not affect the audio, but will reduce H.F. signals.

Servicing the Airlab

- A. Disconnect the mains supply.
- B. Remove the power cable from the back of the console.
- C. Remove the bottom panel of the chassis to get access to the flatcable that connect the modules with eachother.
- D. Remove the cover strips and unscrew the channel module bolts.
- E. Disconnect the flatcable from the modules pcb and lift the channel up at the fader section, and then the other side. Carefully lift the module until you see three connectors mounted to ribbon (flat) cables.
- F. On the PCB part of the connector you will see two ejectors with which to eject the cable header.

Installing the Channel Module

- A. Place the module and plug the three ribbon cable connectors into the PCB connector, ensuring that the ejectors are securely replaced.
- B. Slowly put the module down into the chassis starting from the rear.
- C. Tighten all screws and reconnect the channel.

Servicing the Master Section

- A. Disconnect the Airlab from the mains supply.
- B. Remove all holding screws.
- C. Lift the master section starting from the fader's side.
- D. Remove the connector to the power PCB.
- E. Lift the section upwards until you are able to remove the ribbon cable from the PCBs.
- F. Reverse this procedure to re-mount the master section.

28. INSTALLING / ALIGNMENT OF THE TELCO MODULE

- A. Connect the telephone line with the 'TO PHONE' labeled female XLR and a phone appliance to the female XLR labeled WALL. (See connector pages)

ALIGNMENT OF N-1 (MixMinus)

NOTE: This alignment has already taken place at the factory, however if you later on extend the AIRLAB with another TELCO module you need to follow the next steps for a correct alignment of the N-1 signal for every new installed TELCO module.

1. Power down the AIRLAB.
2. Connect the TELCO module to the right connectors and horizontally lay down the module on the surface of the other modules. Put an isolating material between the TELCO module and the surface of the other modules to avoid damage and shorts. Now locate trimmer VR2 (close to switch "LINE")
3. Activate the 'LINE IN' switch on the TELCO module.
4. Connect an audio source to the LINE IN connector, this can be music or a signal generator.
5. Connect a headphone or power amp to the TELCO SEND CINCH + connector.
6. Check again if there's no short between PCB of the TELCO module and the surface it's put on.
7. Power up the AIRLAB.
8. Move the fader to the 0 dB position. Press the ON switch. Press the PROGRAM switch.
9. CHECK if the CRM outputs this LINE IN signal (No CRM select switches are active) to be sure that you have correctly connected and routed your source.
10. Now adjust the trimmer VR2 to a position where a minimum of signal is heard out of the TELCO OUT Cinch + connector.
11. If you need to adjust the RC balance continue with step 1 of the procedure described below. Otherwise power down the console and install the module again properly.

ADJUSTMENT OF SIDETONE OR R/C BALANCE

The R/C is a one time only adjustment. Only in those situations where the TELCO module is connected to another telephone line a repeated adjustment could be necessary.

NOTE: The R/C balance trimming can only be performed after you have correctly followed the N-1 alignment procedure.

1. Power down the AIRLAB.
2. Connect the TELCO module to the right connectors and horizontally lay down the module on the surface of the other modules. Put an isolating material between the TELCO module and the surface of the other modules to avoid damage and shorts.
3. Connect an audio source to one of the modules and activate the **SUB switch only!!**
4. Connect the telephone system to the TELCO module's WALL connector.
5. Connect a Phone appliance to the "TO PHONE" connector.
6. Check if there is no short between PCB of the TELCO module and the surface it is put on.
7. Power up the AIRLAB.
8. Now dial on the connected Phone appliance a number outside the building.
9. Move the TELCO modules fader to its 0 dB position.
Press the ON switch and activate the **PROG and SUB switch** only. The LINE IN switch should be off (up).
10. CHECK if the CRM outputs this PHONE IN signal coming from the PROG buss, (No CRM select switches are active) to be sure that you have correctly connected and routed your source.
11. Now open the fader on the channel where you have connected your audio and Press the ON switch on that channel.
12. Now you shall hear the audio signal through the TELCO module that is fed from that channel.
13. Now adjust the front panel trimmer VR1 (labeled R-BAL) to a minimum audio position and look for the best combination of C jumper settings and trimmer position.
14. Power down the console and install the module again properly.

As long as the hybrid remains connected to the same "Phone Company", no changes need to be made to this setup. If more TELCO modules need to be aligned the same capacitor value shall be used for all modules so front panel trimming is the only trimming that is left to do for the other modules.

Try to by-pass the in house telephone system if possible. Otherwise it will be extremely difficult to achieve a good alignment. A direct connection with the incoming phone company gives best results.

NOTE: INSTALLATION OF NEW (EXTRA) MODULES

When installing new (extra) modules in your Airlab it's necessary to re-adjust the internal power supply voltages to guarantee a stable performance at all times.

More current is taken from the internal power supply because you have put in more modules now.

It's necessary to adjust the power supply voltage to a precise level of 15 volts for both the positive and negative rails with all modules connected.

Adjustment is performed on the power supply PCB mounted on the bottom of the console located beneath the master section. Three small holes are to be seen at the frontside of the chassis where behind the adjust trimmers are hidden. Power supply voltage is measured across the output terminals of the power supply PCB inside the console.

NOTE: If the power supply voltage is not adjusted to 15 volts again, it may be possible that certain logic functions may not work properly at all times.

29. HOW TO PROGRAM THE AIRLAB

As you might have noticed the Airlab has a LCD in the center section of the master panel with a number of switches positioned below that display.

00:00:00

If you turn on the Airlab you'll notice the following text in the display.

TIMER

This is the menu that's normally active. But before we go into this menu we need to program the Airlab conform to your requirements. This can be done without opening the frame. Very convenient, isn't it?

BEFORE YOU START TAKE NOTICE OF THE FOLLOWING INFORMATION

To save all the work you've done you simply hit the ENTER switch and all settings are stored in the internal memory of the Airlab. If you leave the modules set-up section with the ESC switch, all previously stored data (before you changed it) will still be active.

MAIN MENUS

To leave the timer menu you have to press the UP or DOWN switches in the center of the programming area. If you do this you'll notice the following four main menus.

TIMER (default)
MODULE SETTINGS
MASTER SETTINGS
SYSTEM

The sequence of these main menus can be different whether you hit the UP or DOWN button, but it will never be more than these four activities.

The Module settings for the Triple Line Module and de Triple Dig Module are the same and therefore you don't see a difference between the two models in programming.

MODULE SETTINGS

LINE A ENABLES START TIMER

To see what's under these names you hit the ENTER switch. Lets go to MODULE SETTINGS first and then hit ENTER. The following display on the right will be shown:

This option allows you to select one or more modules, which need to be able to activate the internal TIMER when in Line A input position.

LineA Timerstrt?

HOW TO PROGRAM

The SELECT switches in the modules have a dual function. They select the module you are programming and at the same time you can toggle between starting the timer (LED on) and not starting the timer (LED off) in that module.

This is a very quick way of programming.

If you have already programmed several modules, the moment you enter this menu the LED's located near the SELECT switch will light up on those modules that are programmed to start the TIMER (when the fader is up or the ON switch is activated).

Toggle by SELECT

LINE B ENABLES START TIMER

To enter the next programming possibility you simply hit the DOWN button again and you'll see a new item. See on the right what the LCD shows:

This option allows you to select one or more modules, which need to be able to activate the internal TIMER when in Line B input position.

LineB Timerstrt?

Toggle by SELECT

HOW TO PROGRAM

The SELECT switches in the modules have a dual function. They select the module you are programming and at the same time you can toggle between the active and not active setting. This is a very quick way of programming this function. If you have already programmed several modules, the moment you enter this menu again the LED's located near the SELECT switch will light up, on those modules that are programmed to start the TIMER.

MIC ENABLES TIMER START

To enter the next programming possibility you simply hit the DOWN button again and you will see a new item. See on the right what the LCD shows:

This option allows you to select one or more modules, which need to be able to activate the internal TIMER when in Mic input position. **Not available for Telco Module.**

Mic. Timerstrt?

Toggle by SELECT

HOW TO PROGRAM

The SELECT switches in the modules have a dual function. They select the module you are programming and at the same time you can toggle between the active and not active setting. This is a very quick way of programming this function. If you have already programmed several modules, the moment you enter this menu again the LED's located near the SELECT switch will light up, on those modules that are starting the TIMER

LINE A ENABLES START

To enter the next programming possibility you simply hit the DOWN button again and you will see a new item. See on the right what the LCD shows:

This option allows you to select one or more modules, which need to be able to give a start pulse, when set in Line A input mode. **Always on for Telco module.**

LineA Start?

Toggle by SELECT

HOW TO PROGRAM

The SELECT switches in the modules have a dual function. They select the module you are programming and at the same time you can toggle between the active and not active setting. This is a very quick way of programming this function. If you have already programmed several modules, the moment you enter this menu again the LED's located near the SELECT switch will light up on the modules that are enabled to trigger the fader start.

LINE B ENABLES START

To enter the next programming possibility you simply hit the DOWN button again and you will see a new item. See on the right what the LCD shows:

This option allows you to select one or more modules, which need to be able to give a start, when set in Line B input mode. **Always on for Telco module.**

LineB Start?

Toggle by SELECT

HOW TO PROGRAM

The SELECT switches in the modules have a dual function. They select the module you are programming and at the same time you can toggle between the active and not active setting. This is a very quick way of programming this function. If you have already programmed several modules, the moment you enter this menu again the LED's located near the SELECT switch will light up on the modules that are enabled for the Line B position to trigger the fader start.

MIC ENABLES START

To enter the next programming possibility you simply hit the DOWN button again and you will see a new item. See on the right what the LCD shows:

This option allows you to select one or more modules, which need to be able to give a start pulse, when set in Mic input mode. **Not available for Telco Module.**

Mic. Start?

Toggle by SELECT

HOW TO PROGRAM

The SELECT switches in the modules have a dual function. They select the module you are programming and at the same time you can toggle between the active and not active setting. This is a very quick way of programming this function. If you have already programmed several modules, the moment you enter this menu again the LED's located near the SELECT switch will light up on the modules that are enabled to trigger the fader start when the MIC input is selected.

FADER ACTIVATES START

To enter the next programming possibility you simply hit the DOWN button again and you will see a new item. See on the right what the LCD shows:

This option allows you to select one or more modules, which need to be able to give a start pulse when the fader is opened. **Always off for Telco module.**

Start by Fader?

Toggle by SELECT

HOW TO PROGRAM

The SELECT switches in the modules have a dual function. They select the module you are programming and at the same time you can toggle between the active and not active setting. This is a very quick way of programming this function. If you have already programmed several modules, the moment you enter this menu again the LED's located near the SELECT switch will light up on the modules that are enabled to generate a fader start.

ON SWITCH GENERATES A START PULSE

To enter the next programming possibility you simply hit the DOWN button again and you will see a new item. See on the right what the LCD shows:

This option allows you to select one or more modules, which need to be able to give a start pulse when the ON switch is activated. **Always on for Telco module.**

Start by On?

Toggle by SELECT

HOW TO PROGRAM

The SELECT switches in the modules have a dual function. They select the module you are programming and at the same time you can toggle between the active and not active setting. This is a very quick way of programming this function. If you have already programmed several modules, the moment you enter this menu again the LED's located near the SELECT switch will light up on the modules that are enabled to generate a "start" by way of the ON switch.

CUE SWITCH GENERATES A START PULSE

To enter the next programming possibility you simply hit the DOWN button again and you will see a new item. See on the right what the LCD shows:

This option allows you to select one or more modules, which need to be able to give a start pulse when the CUE switch is activated. **Always on for Telco module.**

Start by Cue?

Toggle by SELECT

HOW TO PROGRAM

The SELECT switches in the modules have a dual function. They select the module you are programming and at the same time you can toggle between the active and not active setting. This is a very quick way of programming this function. If you have already programmed several modules, the moment you enter this menu again the LED's located near the SELECT switch will light up on the modules that are enabled to generate a start by way of the CUE switch.

PULSE OR CONTINUE ON START CONNECTOR

To enter the next programming possibility you simply hit the DOWN button again and you will see a new item. See on the right what the LCD shows:

This option allows you to set the type of start signal on the Start jack of one or more modules. You can choose between Pulse and Continues. **Always Continues for Telco module.**

Pulse */ Cont 0?

Toggle by SELECT

HOW TO PROGRAM

The SELECT switches in the modules have a dual function. They select the module you are programming and at the same time you can toggle between the active and not active setting. This is a very quick way of programming this function. If you have already programmed several modules, the moment you enter this menu again the LED's located near the SELECT switch will light up on the modules that are giving a Pulse on the start jack.

REMOTE CUE POSSIBLE IN LINE A MODE

To enter the next programming possibility you simply hit the DOWN button again and you will see a new item. See on the right what the LCD shows:

This option allows you to set if the CUE must be activated by an incoming remote on one or more modules, when set in Line A input mode.

LineA Rem. Cue?

Toggle by SELECT

HOW TO PROGRAM

The SELECT switches in the modules have a dual function. They select the module you are programming and at the same time you can toggle between the active and not active setting. This is a very quick way of programming this function. If you have already programmed several modules, the moment you enter this menu again the LED's located near the SELECT switch will light up on the modules that are capable of activating the CUE by a remote switch.

REMOTE CUE POSSIBLE IN LINE B MODE

To enter the next programming possibility you simply hit the DOWN button again and you will see a new item. See on the right what the LCD shows:

This option allows you to set if the CUE must be activated by an incoming remote on one or more modules, when set in Line B input mode.

LineB Rem. Cue?

Toggle by SELECT

HOW TO PROGRAM

The SELECT switches in the modules have a dual function. They select the module you are programming and at the same time you can toggle between the active and not active setting. This is a very quick way of programming this function. If you have already programmed several modules, the moment you enter this menu again the LED's located near the SELECT switch will light up on the modules that are programmed to activate the CUE by a remote switch in line B input mode.

REMOTE CUE POSSIBLE IN MIC MODE

To enter the next programming possibility you simply hit the DOWN button again and you will see a new item. See on the right what the LCD shows:

This option allows you to set if the CUE must be activated by an incoming remote on one or more modules, when set in Mic input mode. This option is necessary for COUGH/COMM. **Not available for Telco Module.**

Mic. Rem. Cue?

Toggle by SELECT

HOW TO PROGRAM

The SELECT switches in the modules have a dual function. They select the module you are programming and at the same time you can toggle between the active and not active setting. If you had already programmed several modules, the moment you enter this menu again the LED's located near the SELECT switch will go on, on those modules that are capable of activating the CUE by a remote switch when the MIC input is selected.

WHICH CHANNEL IS YOUR DJ CHANNEL

To enter the next programming possibility you simply hit the DOWN button again and you will see a new item. See on the right what the LCD shows:

This option allows you to set one or more modules in DJ mode.

Not available for Telco Module.

DJ. Module?

Toggle by SELECT

HOW TO PROGRAM

The SELECT switches in the modules have a dual function. They select the module you are programming and at the same time you can toggle between the active and not active setting. This is a very quick way of programming this function. If you have already programmed several modules, the moment you enter this menu again the LED's located near the SELECT switch will light up on the modules that are set in DJ mode.

ON WHICH CHANNEL IS YOUR ANNOUNCER MIC

To enter the next programming possibility you simply hit the DOWN button again and you will see a new item. See on the right what the LCD shows:

This option allows you to set one module in Announcer mode.

Note: you can't select more than one Announcer module.

Not available for Telco Module.

Ann. Module?

Toggle by SELECT

HOW TO PROGRAM

The SELECT switches in the modules have a dual function. They select the module you are programming and at the same time you can toggle between the active and not active setting. This is a very quick way of programming this function. If you have already programmed several modules, the moment you enter this menu again the LED's located near the SELECT switch will light up on the modules that are programmed to be an Announcer module.

ON WHICH CHANNEL IS YOUR STUDIO MIC

To enter the next programming possibility you simply hit the DOWN button again and you will see a new item. See on the right what the LCD shows:

This option allows you to set one or more modules in Studio mode. **Not available for Telco Module.**

Studio Module?

Toggle by SELECT

HOW TO PROGRAM

The SELECT switches in the modules have a dual function. They select the module you are programming and at the same time you can toggle between the active and not active setting. This is a very quick way of programming this function. If you have already programmed several modules, the moment you enter this menu again the LED's located near the SELECT switch will light up on the modules that are programmed to handle the Studio MIC input.

ON AIR-1 ACTIVE FOR LINE A

To enter the next programming possibility you simply hit the DOWN button again and you will see a new item. See on the right what the LCD shows:
This option allows you to set one or more modules to toggle the ON-AIR-1 relay, when in Line A input mode.

LineA On Air-1?

Toggle by SELECT

HOW TO PROGRAM

The SELECT switches in the modules have a dual function. They select the module you are programming and at the same time you can toggle between the active and not active setting. This is a very quick way of programming this function. If you have already programmed several modules, the moment you enter this menu again the LED's located near the SELECT switch will light up on the modules that are toggling the ON-AIR 1 relay when line A is selected.

ON AIR-1 ACTIVE FOR LINE B

To enter the next programming possibility you simply hit the DOWN button again and you will see a new item. See on the right what the LCD shows:
This option allows you to set one or more modules to toggle the ON-AIR-1 relay, when in Line B input mode.

LineB On Air-1?

Toggle by SELECT

HOW TO PROGRAM

The SELECT switches in the modules have a dual function. They select the module you are programming and at the same time you can toggle between the active and not active setting. This is a very quick way of programming this function. If you have already programmed several modules, the moment you enter this menu again the LED's located near the SELECT switch will light up on the modules that are toggling the ON-AIR 1 relay when line B is selected.

ON AIR-1 ACTIVE FOR MIC

To enter the next programming possibility you simply hit the DOWN button again and you will see a new item. See on the right what the LCD shows:
This option allows you to set one or more modules to toggle the ON-AIR-1 relay, when in Mic input mode. **Not available for Telco Module.**

MIC On Air-1?

Toggle by SELECT

HOW TO PROGRAM

The SELECT switches in the modules have a dual function, they select the module you are programming and at the same time you can toggle between the active and not active setting. This is a very quick way of programming this function. If you had already programmed several modules, the moment you enter this menu again the LED's located near the SELECT switch will go on, on those modules that are toggling the ON-AIR 1 relay when MIC is selected.

ON AIR-2 ACTIVE FOR LINE A

To enter the next programming possibility you simply hit the DOWN button again and you will see a new item. See on the right what the LCD shows:
This option allows you to set one or more modules to toggle the ON-AIR-2 relay, when in Line A input mode.

LineA On Air-2?

Toggle by SELECT

HOW TO PROGRAM

The SELECT switches in the modules have a dual function. They select the module you are programming and at the same time you can toggle between the active and not active setting. This is a very quick way of programming this function. If you have already programmed several modules, the moment you enter this menu again the LED's located near the SELECT switch will light up on the modules that are toggling the ON-AIR 2 relay when line A is selected.

ON AIR-2 ACTIVE FOR LINE B

To enter the next programming possibility you simply hit the DOWN button again and you will see a new item. See on the right what the LCD shows:
This option allows you to set one or more modules to toggle the ON-AIR-2 relay, when in Line B input mode.

LineB On Air-2?

Toggle by SELECT

HOW TO PROGRAM

The SELECT switches in the modules have a dual function. They select the module you are programming and at the same time you can toggle between the active and not active setting. If you have already programmed several modules, the moment you enter this menu again the LED's located near the SELECT switch will light up on the modules that are toggling the ON-AIR 2 relay when line B is selected.

ON AIR-2 ACTIVE FOR MIC

To enter the next programming possibility you simply hit the DOWN button again and you will see a new item. See on the right what the LCD shows:

This option allows you to set one or more modules to toggle the ON-AIR-1 relay, when in Mic A input mode. **Not available for Telco Module.**

Mic OnAir-2?

Toggle by SELECT

HOW TO PROGRAM

The SELECT switches in the modules have a dual function. They select the module you are programming and at the same time you can toggle between the active and not active setting. If you have already programmed several modules, the moment you enter this menu again the LED's located near the SELECT switch will light up on the modules that are toggling the ON-AIR 2 relay when MIC is selected.

ON AT START UP

To enter the next programming possibility you simply hit the DOWN button again and you will see a new item. See on the right what the LCD shows:

This option allows you to set one or more modules to be default ON when powering up the console.

On at Power up?

Toggle by SELECT

HOW TO PROGRAM

The SELECT switches in the modules have a dual function. They select the module you are programming and at the same time you can toggle between the active and not active setting. This is a very quick way of programming this function. If you have already programmed several modules, the moment you enter this menu again the LED's located near the SELECT switch will light up on the modules that are turning to their ON mode when the power comes up.

MIC CONNECTED AT LINE A

To enter the next programming possibility you simply hit the DOWN button again and you will see a new item. See on the right what the LCD shows:

This option allows you to hook up a Mic to Line A on one or more modules. The COUGH/COMMUNICATION feature automatically becomes available when the module is in Line A mode. **Not available for Telco Module.**

MIC at Line A?

Toggle by SELECT

HOW TO PROGRAM

The SELECT switches in the modules have a dual function. They select the module you are programming and at the same time you can toggle between the active and not active setting.

This is a very quick way of programming this function. If you have already programmed several modules, the moment you enter this menu again the LED's located near the SELECT switch will light up on the modules that are assigned for MIC-mode in LINE A.

MIC CONNECTED AT LINE B

To enter the next programming possibility you simply hit the DOWN button again and you will see a new item. See on the right what the LCD shows:

This option allows you to hook up a Mic to Line B on one or more modules. The COUGH/COMMUNICATION feature automatically becomes available when the module is in Line B mode. **Not available for Telco Module.**

MIC at Line B?

Toggle by SELECT

HOW TO PROGRAM

The SELECT switches in the modules have a dual function. They select the module you are programming and at the same time you can toggle between the active and not active setting. This is a very quick way of programming this function. If you have already programmed several modules, the moment you enter this menu again the LED's located near the SELECT switch will light up on the modules that are assigned for MIC-mode in LINE B.

REMOTE ON POSSIBLE IN MIC MODE

To enter the next programming possibility you simply hit the DOWN button again and you will see a new item. See on the right what the LCD shows:

This allows you to operate the ON switch on one or more selected modules by corresponding remote, when the Mic input is selected. **Not available for Telco Module.**

HOW TO PROGRAM

The SELECT switches in the modules have a dual function. They select the module you are programming and at the same time you can toggle between the active and not active setting. If you have already programmed several modules, the moment you enter this menu again the LED's located near the SELECT switch will light up on the modules that are capable of activating the ON by a remote switch when the MIC input is selected.

REMOTE ON POSSIBLE IN LINE A MODE

To enter the next programming possibility you simply hit the DOWN button again and you will see a new item. See on the right what the LCD shows:

This allows you to operate the ON switch on one or more selected modules by the corresponding remote, when the Line A input is selected. **Always off for Telco module.**

HOW TO PROGRAM

The SELECT switches in the modules have a dual function. They select the module you are programming and at the same time you can toggle between the active and not active setting. This is a very quick way of programming this function. If you have already programmed several modules, the moment you enter this menu again the LED's located near the SELECT switch will light up on the modules that are capable of activating the ON by a remote switch.

REMOTE ON POSSIBLE IN LINE B MODE

To enter the next programming possibility you simply hit the DOWN button again and you will see a new item. See on the right what the LCD shows:

This allows you to operate the ON switch on one or more selected modules by the corresponding remote, when the Line B input is selected. **Always off for Telco module.**

LineB Rem. On?

Toggle by SELECT

HOW TO PROGRAM

The SELECT switches in the modules have a dual function. They select the module you are programming and at the same time you can toggle between the active and not active setting. This is a very quick way of programming this function. If you have already programmed several modules, the moment you enter this menu again the LED's located near the SELECT switch will light up on the modules that are capable of activating the ON by a remote switch in line B input mode.

SWITCH START

To enter the next programming possibility you simply hit the DOWN button again and you will see a new item. See on the right what the LCD shows:

With this option active the module is always ON and operation On-switch will only trigger the start-remote. **Not available for Telco Module.**

Switch Start?

Toggle by SELECT

HOW TO PROGRAM

The SELECT switches in the modules have a dual function. They select the module you are programming and at the same time you can toggle between the active and not active setting. This is a very quick way of programming this function. If you have already programmed several modules, the moment you enter this menu again the LED's located near the SELECT switch will light up on the modules that are capable of Switch Start.

IMPORTANT INFORMATION

To save all the work you have done you simply hit the ENTER switch and all settings are stored in the internal memory of the Airlab.

Pressing the ESC switch instead will discard all the changed settings in the last session.

You have now completed the modules set-up and it is now time to go to the Master settings.

30. MASTER SETTINGS

To enter this part of the programming hit the EXIT button and you will see that the LCD returns to its TIMER menu. Now hit the UP or DOWN switch again until you see the text MASTER SETTINGS. This brings you into the master settings menu. Now push the ENTER switch to enter the four master programming possibilities.

AUTO CUE RESET

Use the YES and NO button to switch 'Auto cue Reset' option on and off.

HOW TO PROGRAM

With the YES and NO switches you can activate or de-activate this option. Don't forget to confirm changes you made in software with the enter switch.

CUE TO CRM

CUE to CRM is an option, which enables you to route the CUE signal to the CRM speakers.

HOW TO PROGRAM

With the YES and NO switches you can activate or de-activate this option. Don't forget to confirm changes you made in software with the enter switch.

CUE to CRM?

YES

AUTO COMMUNICATION

When this feature is activated you can create a communication link from a remotely connected SiCo box to an announcer module.

To make this work the 'Mic Rem. CUE' option needs to be activated.

HOW TO PROGRAM

With the YES and NO switches you can activate or de-activate this option. Don't forget to confirm changes you made in software with the enter switch.

Auto Comm?

YES

RS232

The RS232 option enables you to connect the Airlab to a PC.

Basically The Airlab software is a graphical user interface version of the software structure inside the Airlab.

HOW TO PROGRAM

With the YES and NO switches you can activate or de-activate this option. Don't forget to confirm changes you made in software with the enter switch.

Enable RS 232?

YES

IMPORTANT INFORMATION

To save all the work you have done you simply hit the ENTER switch and all settings are stored in the internal memory of the Airlab.

Pressing the ESC switch instead will discard all the changed settings in the last session.

31. SYSTEM SETUP

You have now completed the master set-up and it is now time to go to the System settings. To enter this part of the programming hit the EXIT button to leave the master settings without saving changes or hit the ENTER switch to leave the master settings with saving changes.

The System menu consists out of 5 submenus, which are:

CONFIGURATION

RECALL

STORE

RECALL Memory CARD (only visible with inserted memory card)

STORE Memory CARD (only visible with inserted memory card)

Select these sub menus by pushing the UP or DOWN buttons.

CONFIGURATION

The first item in the System menu is the configuration screen. This screen displays the current configuration of the Airlab. XX represents the number of Stereo modules available on the console and YY represent the number of Telco modules available on the console.

Config

StMod:XX Telco:YY

RECALL

In the Recall menu you can recall a stored setup from the internal Airlab memory.

By pressing the ENTER switch the data will be recalled from the internal memory. Subsequently pressing the ESC switch, the Recall menu will be left without recalling.

Recall

Press Enter/Esc

STORE

In the Store menu you can store a setup to the internal memory.

By pressing the ENTER switch the actual data will be stored to memory. Subsequently by pushing the ESC switch, the Store menu will be left.

Store

Press Enter/Esc

RECALL Memory Card

In the Recall memory card menu you can recall a stored setup from a Memory card.

By pressing the ENTER switch the actual data will be recalled from an inserted memory card.

Subsequently by pushing the ESC switch the Recall Memory card menu will be left.

STORE Memory Card

In the Store Memory Card menu you can store a set-up to an inserted memory card. By pressing the ENTER switch the actual data will be stored to an inserted Memory Card.

Subsequently by pushing the ESC switch the Store Memory card menu will be left.

Store Mem. Card

Press Enter/Esc

All the above explained programming and storing of data can be performed on a Windows PC. You need to connect the RS232 (USB) connector of the Airlab to the RS232 connector of your PC and load the Airlab software. All module and master programming can be dealt with on one PC screen. In this way you will have a total view of your settings on one screen. This can be edited and when you sorted out all your settings it can be downloaded to the Airlab's memory and subsequently stored on a memory card.

32. TIMER

As earlier mentioned the Airlab has a built in Timer, which is practical and easy to use. The Timer menu is the basic menu that the Airlab always shows.

To activate the timer it is necessary to first program the modules and make up your mind which modules and in which mode they should trigger the Timer.

Any module that has been programmed to start the timer shall trigger the timer and the clock is running, reading from left to right: hours, minutes and seconds.

The moment you pull down a fader or switch an ON switch off the timer stops showing the exact time the module has been active.

As soon as you open the module again, the timer will be reset it and starts all over again.

The Timer can also be started and stopped by the ENTER switch.
It goes like this:

1. With ENTER the timer will be reset and starts or continues to run.
2. With ESC the timer will be reset and when it runs it continues to do so.

00:00:00

TIMER

33. MENU DIAGRAM

The menu diagram displays the menu structure as it is programmed in the Airlab.

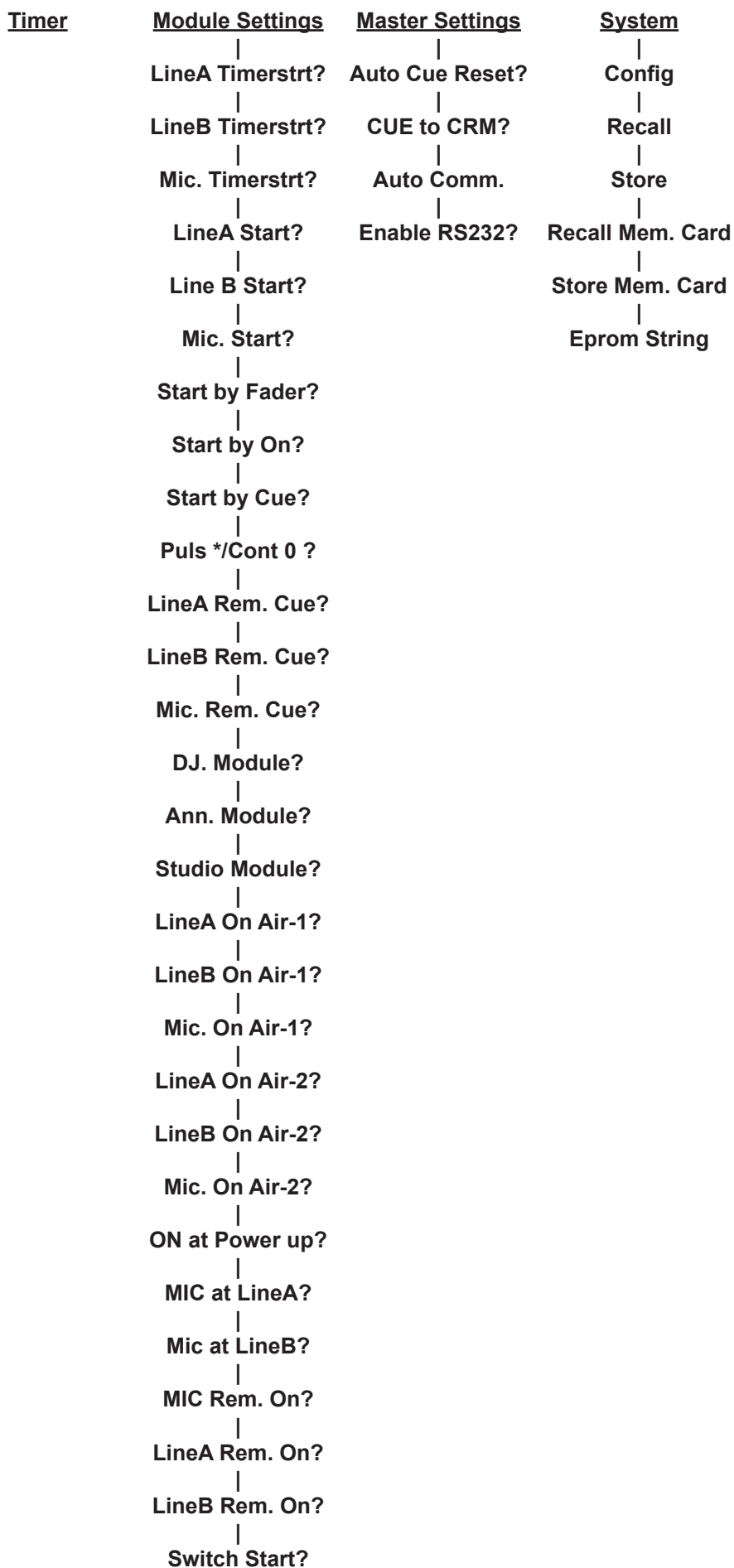

34. Windows Software

The RS232 communication option enables you to manage the Airlab programming from a remotely connected PC. The main advantage is that this gives you a much better overview on all the available settings that can be made. All the custom settings made can be saved in a file. That way you can create your own presets. The settings made can be saved to chipcard. Each user can have a personal chipcard with his or hers customized setting for the Airlab.

INSTALLATION

The installation software comes on an USB stick. Please run the setup.exe file to begin the installation. During the setup you can choose the path for the installation directory. During the installation process a program folder will be created together with a desktop icon. From these locations you can startup the application.

GETTING STARTED

Before you run the software be sure to connect the Airlab to the PC correctly. If this isn't the case you'll see the following error message: Clicking the OK button continues to startup the Airlab application but without any software control. The screen looks like this:



Figure 20: Airlab not connected



Figure 19: No Airlab found

After you have connected the Airlab console correctly you have two options. You can reconnect to the Airlab using the 'Connection' menu or you can reboot the application.

If the Airlab is connected correctly you'll see the following screen Figure 21: Airlab Main Screen 21). You'll notice that the screen is divided in multiple sections. Each section is individually discussed in this chapter.

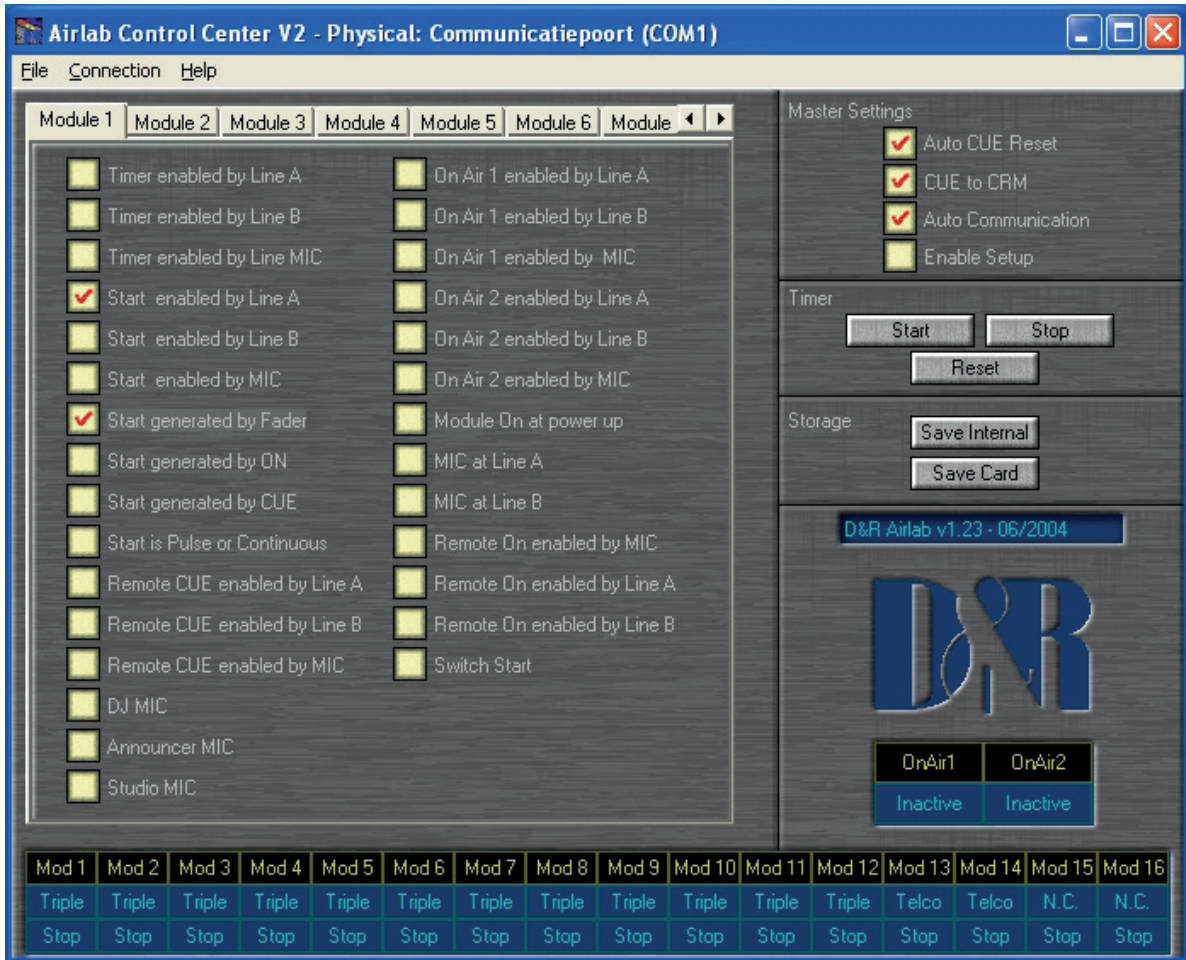

Figure 21: Airlab Main Screen

Figure 22: Status bar 22 displays a summary of all the modules in the Airlab.

Mod 1	Mod 2	Mod 3	Mod 4	Mod 5	Mod 6	Mod 7	Mod 8	Mod 9	Mod 10	Mod 11	Mod 12	Mod 13	Mod 14	Mod 15	Mod 16
Triple	Triple	Triple	Triple	Triple	Triple	Triple	Triple	Triple	Triple	Triple	Triple	Telco	Telco	N.C.	N.C.
Stop	Stop	Stop	Stop	Stop	Stop	Stop	Stop	Stop	Stop	Stop	Stop	Stop	Stop	Stop	Stop

Figure 22: Status bar

As you can see we can have a total of 16 modules in the Airlab. The configuration, as shown in the second column, consists from 12 triple line modules and 2 Telco modules. The last two slots aren't used in this case. The third column represents the status of the start remote on the rear side of each channel.

The section displayed by 23, displays the On Air status of the Airlab. There's also a small window in this section, which displays the software version present in the Airlab.



Figure 23: Master Settings

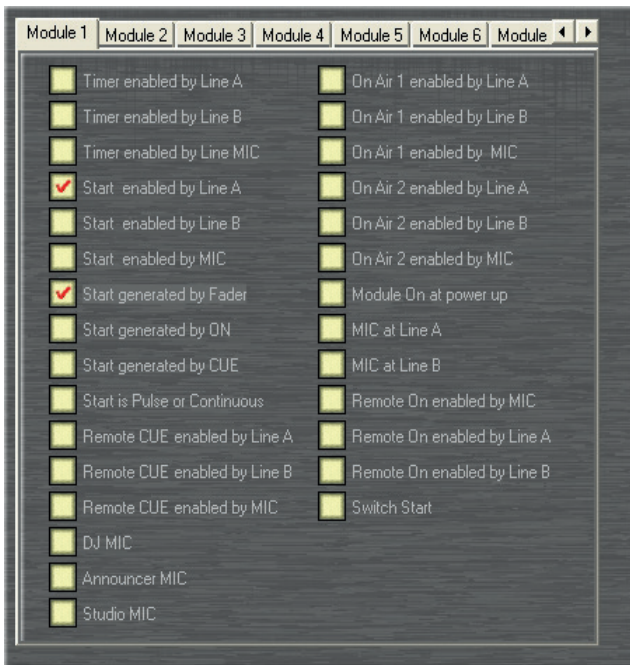

Figure 24: Triple Module Settings

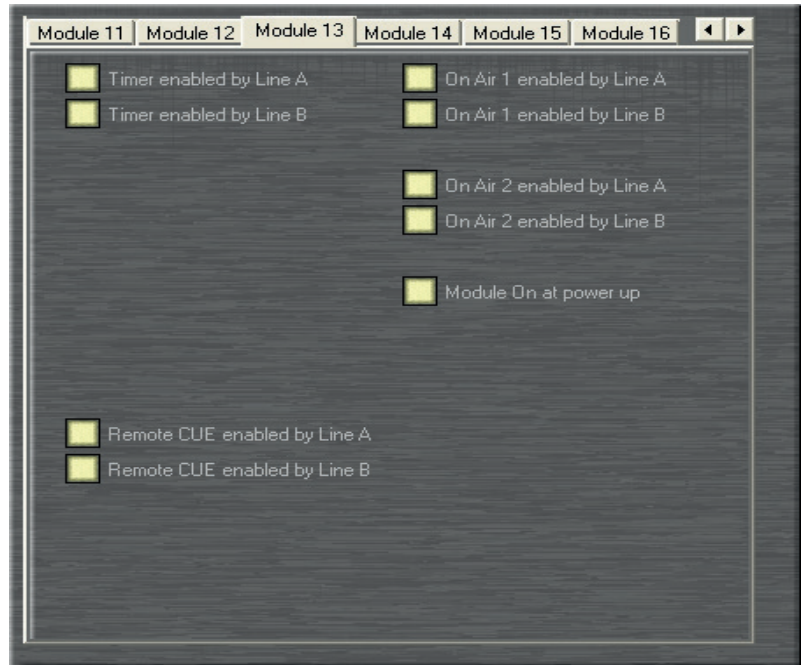

Figure 25: Telco Module Settings

Figure 24 and Figure 25 display the module settings for the Telco and the Line modules. Basically this is a graphical overview of the menu structure in the Airlab. The graphical user interface allows you to make changes very easily and very fast.

For a detailed overview off all module settings you can read section 14.1 of this manual.

The Master settings in the application are nearly identical to the Master setting of the Airlab.

The main difference is the fourth option.

The fourth Master Setting in the Airlab is the Enable 'RS232' setting.

This option enables or disables the COM port on the rear side of the airlab.

The fourth Master Setting in the application is the 'Enable Setup' setting.

This option allows or denies users to enter the menu of the Airlab from the console.

This is a protection feature.

For more detailed information on the Master Settings you can read section 14.2 of this manual.

The Timer section (Figure 27) allows you to control the Timer on the Airlab from the PC.

The Storage section (Figure 28) allows you to save the changes you made in the Airlab memory or on a chipcard.

The 'Save Card' button is only available when a chipcard is inserted.

The main advantage of the chipcard is that you can make presets for multiple users.

And thanks to the 'Enable Setup' option you can make sure that they won't mess around with the settings in the console.

The File => Save and the File => Open options allow you to save the changes you've made to one or more files so that you can re-open them later again to restore your personal setting again.

35. SPECIFICATIONS

INPUTS:

Mic inp. bal. 2 kOhm - 128 dBr (+/- 40 dB gain range plus 30 dB of trim range).

Line inp. bal 10 kOhm +/- 20 dB gain range.

Insert level: -10dbV

Telco input (XLR) 10 kOhm bal. +4 dBu nominal.

CMRR: mic input max. gain: 1kHz 85 dB.

Line input max. gain 1 kHz 30 dB.

EQUALISATION:

+/- 12 dB @ 10 kHz shelving.

+/- 12 dB @ 1 kHz bell curve.

+/- 12 dB @ 60 Hz bell curve.

Low Cut: 80 Hz, 12 dB per octave (Mic only)

Low Cut: 200Hz, 6 dB per octave (Telco only).

High Cut: 8 kHz, 6 dB per octave (Telco only).

OUTPUTS:

Program left/right: +6 dBu electronically balanced (transformer balancing optional).

Sub: +6 dBu electronically balanced. (transformer balancing optional)

All other outputs: +6 dBu unbal.

OVERALL:

Frequency response: 20-20.000 Hz +/-0.5 dB.

Harmonic distortion: 0.035% (VCA in, 2nd harm).

Crosstalk: less than -90 dBr.

Noise: -86 dBr.

Headroom: +22 dB internal, 20 dB on outputs.

Mix-Minus rejection: @1 kHz -60 dB.

Channel fader attenuation: 1 kHz, 100 dB.

WEIGHT:

Airlab loaded with 16 modules: 26 kg (58 lb).

DIMENSIONS

Drop though mounting 775 mm Width, 415 mm Depth

When inserting the Airlab in its mounting hole first position the armrest side in the hole and slowly lower the back side holding the wood ends on either side of the console. Mount the back panel after installation to finish the job neatly.

Color scheme as per 1-1-2015:

Front panels : RAL 9006

Text : RAL 7016

Frame : RAL 9006

36. STUDIO REMOTE DT

The Airlab Studio remote is designed to be the communication interface between the control room and the announcer or guest. It has a built in headphone amp, a remote connector to be wired via a shielded stereo cable to the related Airlab channel, and a very convenient COUGH/COMMUNICATION button. We shall describe all functions in detail now.

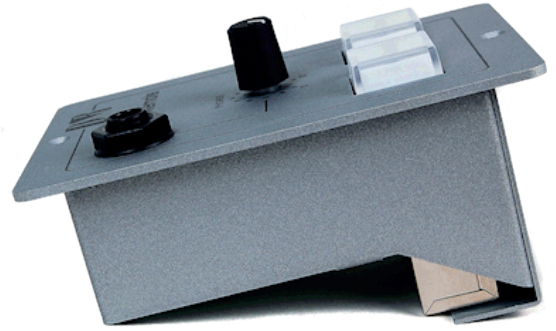

COUGH/SIGNALLING IN MIC MODE

This useful feature has two important functions:

1. Cough/communication,
2. 'Mic-on'

Cough/Communication,

A shielded stereo cable has to be connected between the Studio Remote unit and the Airlab input channel that needs to be communicated to.

Using the push-button during broadcast, the announcer can temporarily mute the microphone in order to cough (where the name comes from). At the same time his microphone will be routed to the cue system, in order to give him the opportunity to communicate with the engineer/producer.

Mic-on,

When the channel is active a voltage is applied between Tip (+) and Sleeve (0V), which can be used to activate a LED (red) (in this case the internal LED of the Studio Remote unit).

In addition to the localized 'mic-on' signaling, there is also a master signal in the master section.

The ONAIR signaling outputs 1 and 2 offer the option of driving external red light indicators in the studio by way of a relay.

The input jack of the Studio remote unit needs to be wired to the master of the Airlab, Guest or Announcer outputs or whatever suits your purpose mostly.

The output jack is wired parallel to the input phone jack



37. PRODUCT SAFETY

This product is manufactured with the highest standards and is double checked in our quality control department for reliability in the "HIGH VOLTAGE" section.

CAUTION

Never remove any panels, or open this equipment. No user serviceable parts inside. Equipment power supply must be grounded at all times. Only use this product as described, in user manual or brochure. Do not operate this equipment in high humidity or expose it to water or other liquids. Check the AC power supply cable to assure secure contact. Have your equipment checked yearly by a qualified dealer service center. Hazardous electrical shock can be avoided by carefully following the above rules.

PLEASE READ THE FOLLOWING INFORMATION VERY CAREFULLY

Especially in sound equipment on stage the following information is essential to know. Voltage and current cause an electrical shock. Actually it's the current that causes the shock. In practice the higher the voltage the higher the current will be and the higher the shock. But there is another thing to consider and it is resistance. When the resistance in Ohms is high between two poles, the current will be low and visa versa. All three of these voltage, current and resistance are important in determining the effect of an electrical shock.

However, the severity of a shock is primarily determined by the amount of current flowing through a person. A person can feel a shock because the muscles in a body respond to electric current. Current can also be fatal when it causes the chest muscles to contract and stop breathing. At what potential is current dangerous? Well the first feeling of current is a tingle at 0.001 Amp of current.

The current between 0.1 Amp and 0.2 Amp is fatal. Imagine that your home fuses of 16 Amp can handle 200 times more current than is necessary to kill.

How does resistance affect the shock a person feels? A typical resistance between your two hands "dry" condition could be well over 100,000 Ohm.

Always earth all your equipment by the grounding pin in your mains plug Hum loops should be only cured by proper wiring and isolation input/output transformers. Replace fuses always with the same type and rating after the equipment has been turned off and unplugged. If the fuse blows again you have an equipment failure. Do not use it again and return it to your dealer for repair. And last but not least be careful not to touch a person being shocked as you, yourself could also be shocked. Once removed from the shock, have someone send for medical help immediately

Always keep the, on the previous page, mentioned information in mind when using electrically powered equipment.

D&R Electronica b.v.
Rijnkade 15b
1382 GS WEESP
NETHERLANDS
Phone: +31 (294) 418 014*
Website: <http://www.dnrbroadcast.com>
mail: info@d-r.nl

38. DECLARATION OF CONFORMITY

DECLARATION OF CONFORMITY

Manufacturers Name : D&R Electronica b.v.
Manufacturers Address : Rijnkade 15B
: 1382 GS Weesp
: The Netherlands

Declares that the product AIRLAB series
Conforms to the following product specifications:

EMC : NEN-EN 55103-1 1995
: NEN-EN 55103-2 1995
: NEN-EN 55013-1 1994

Supplementary Information:

The product herewith complies with the requirements of the EMC Directive 89/336/EEC (1989)
as amended by the CE Marking Directive 93/68/EEC (1993).

D&R Electronica b.v.
Rijnkade 15 B
1382 GS WEESP
The Netherlands

President of Engineering
Date: January 1, 2022

Name	Title
Duco de Rijk	Compliance Program Manager

Signature

39. DISCLAIMER

Due to a policy of continuous product improvement, D&R Electronica B.V. reserves the right to change specifications, appearance and performance without prior notice.

Since the use of this information, and the conditions by which the products are used are beyond the control of D&R Electronica B.V., it is the obligation of the owner and/or the equipment operator to determine the correct and safe selection, settings and conditions of use of the equipment and products.

To the extent that the law permits, any liability which may be incurred as a result of the use or future use of a product manufactured or sold by D&R Electronica B.V. is limited to the cost of repairing or replacing the failed product or component at the discretion of D&R Electronica B.V., either within, or outside of warranty periods, and does not extend to any loss or damage which may be caused as a consequence of misuse or failure of the equipment or products.

D&R Electronica B.V. shall not in any event be liable for economic lost of profits including without limitation any incidental or consequential damage, expenses or other damages arising out of the use or inability to use the product and/or software even if D&R Electronica B.V. has been advised of the possibility of such a damage or for any claim by another party.

You agree to indemnify, hold harmless, and defend D&R Electronica B.V., its parent, and their licensors, suppliers, officers, directors, employees, agents, affiliates, subsidiaries (collectively "Indemnified Parties") from and against any and all liability incurred by or made against the Indemnified Parties in connection with any claim arising from or related to your use.